



COMMERCIAL VEHICLE AUCTIONS LTD
THE UK'S MOST ESTABLISHED COMMERCIAL VEHICLE AUCTIONEERS

Carr Hill Industrial Estate
Doncaster
DN4 8DE

01302 732600 | cva.noreply@cva-auctions.co.uk

VEHICLE INSPECTION REPORT

PF20JYC

Mercedes-Benz Sprinter 314 CDI

Inspection		Vehicle	
Serious Damage?	No	VAT	Plus VAT
		V5	Present

Details

Reg. date	24/08/2020	VIN	W1V9076352P256127	CAP Below	£5,200.00
Year	2020	Body Style	Panel Van L3	Gearbox	AUTOMATIC
Mileage	184,949 Miles Warranted	MOT Due	12/07/2026	Gears	6
Fuel Type	Diesel	CAP Clean	£7,425.00		
Colour	WHITE	CAP Average	£6,500.00		

AD-BLUE, SIDE LOADING DOOR

Tyres

NSF
NSR
OSF
OSR
Spare

Features

- Rear parking sensor
- Front electric windows

Photos





Condition Check

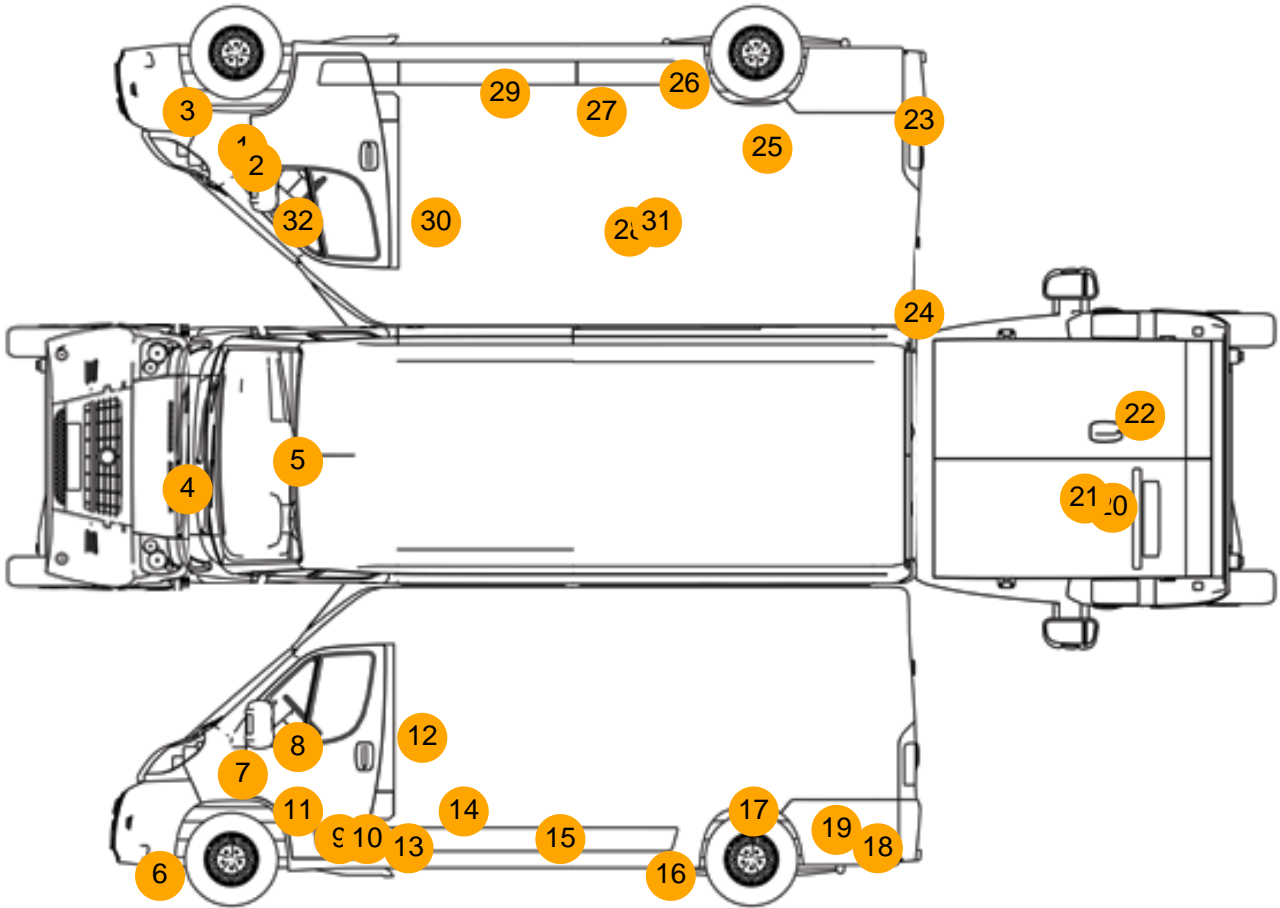

Damage Photos



1: Wing of
Dented
With Paint Damage

2: Wing of
Dented
With Paint Damage



3: Bumper Front Moulding
Scuffed (Unpainted)
Over 100mm

4: Bonnet
Chipped
Multiple Chips



5: Screen Front
Chipped
Up To 10mm

6: Bumper Front Moulding
Scuffed (Unpainted)
Over 100mm



7: Wing nsf
Scratched
Over 25mm Thru Paint

8: Door Mirror Assy nsf
Scuffed (Unpainted)
Over 100mm



9: Door nsf
Dented
With Paint Damage

10: Door Moulding nsf
Scuffed (Unpainted)
Over 100mm



11: Door nsf
Scratched
Over 25mm Not Thru Paint

12: B Post ns
Scratched
Up To 25mm Thru Paint



13: B Post ns
Dented
With Paint Damage

14: Door nsr
Dented
Over 30mm



15: Door Moulding nsr
Scuffed (Unpainted)
Over 100mm

16: Qtr Panel nsr
Dented
With Paint Damage



17: Qtr Panel nsr
Scratched
Over 25mm Not Thru Paint

18: Qtr Panel nsr
Dented
Between 10mm + 30mm



19: Qtr Panel Moulding ns
Scuffed (Unpainted)
Over 100mm

20: Door nsr
Dented
With Paint Damage

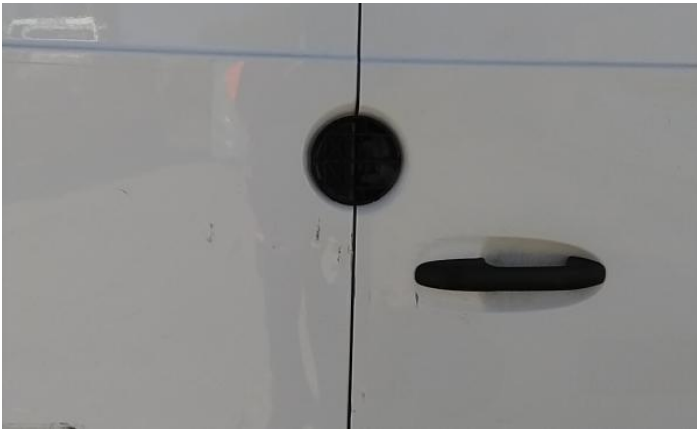

21: Badgedecal Rear
Missing
Replace

22: Door osr
Dented
Over 30mm



23: Bumper Rear Moulding
Scuffed (Unpainted)
Over 100mm

24: Qtr Panel osr
Dented
Over 30mm



25: Qtr Panel osr
Scratched
Over 25mm Not Thru Paint

26: Qtr Panel osr
Dented
With Paint Damage



27: Qtr Panel Trim os
Scuffed
Over 25mm

28: Qtr Panel osr
Dented
With Paint Damage

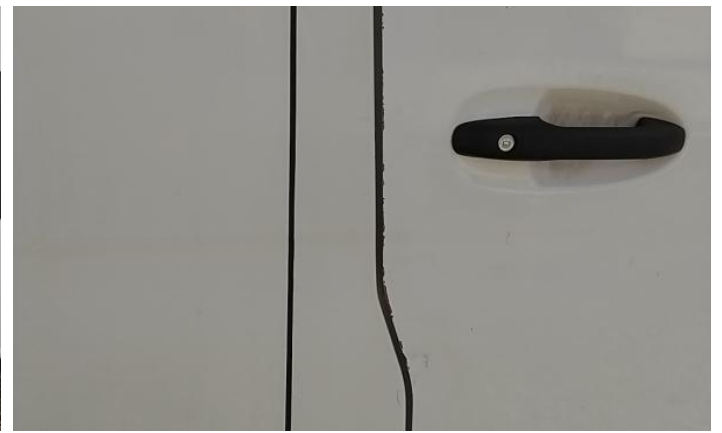

29: Qtr Panel Moulding os
Scuffed (Unpainted)
Over 100mm

30: Door osf
Chipped
Edge Chip



31: Qtr Panel osr
Dented
With Paint Damage

32: Door Mirror Assy osf
Scuffed (Unpainted)
Over 100mm



33: Carpets Front
 Holed
 Over 3mm

Interior

Carpet Condition	Average	Upholstery Condition	Average
Seat Condition	Average	Odour	No
Engine Runs	OK	Gearbox 1st and Reverse Test	OK
Brakes	OK	Clutch Slip Test from Static	OK
Parking Brake	OK	Gearbox Static Gear Selection (engine running)	OK
		No Excessive Smoking	OK
EML light illuminated	OK	Oil warning light illuminated	OK
Airbag light illuminated	OK	DPF light illuminated	OK
ABS light illuminated	OK	Service indicator light illuminated	OK