



COMMERCIAL VEHICLE AUCTIONS LTD  
THE UK'S MOST ESTABLISHED COMMERCIAL VEHICLE AUCTIONEERS

Carr Hill Industrial Estate  
Doncaster  
DN4 8DE

01302 732600 | cva.noreply@cva-auctions.co.uk

# VEHICLE INSPECTION REPORT

**PJ20UDE**

## Mercedes-Benz Sprinter 314 CDI

Inspection		Vehicle	
Serious Damage?	No	VAT	Plus VAT
		V5	Present

Details					
Reg. date	24/07/2020	Colour	WHITE	CAP Average	£4,575.00
Year	2020	VIN	W1V9076352P253673	CAP Below	£3,675.00
Mileage	266,448 Miles Warranted	Body Style	Panel Van L3	Gearbox	AUTOMATIC
Fuel Type	Diesel	MOT Due	12/03/2027	Gears	6
GVW	3500kg	CAP Clean	£5,250.00		

AD-BLUE, SIDE LOADING DOOR

Tyres
NSF
NSR
OSF
OSR
Spare

## Features

- Rear parking sensor
- Front electric windows

## Photos

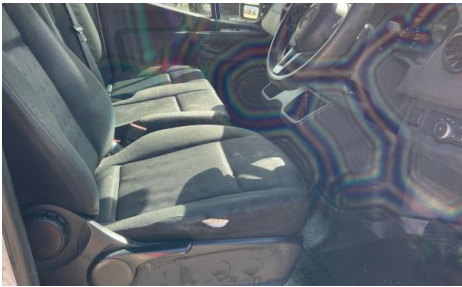

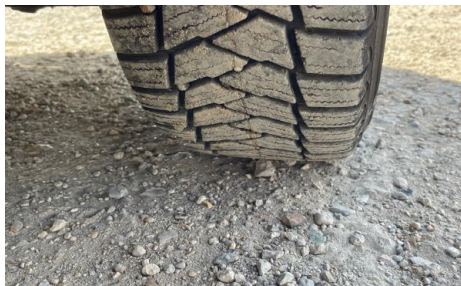
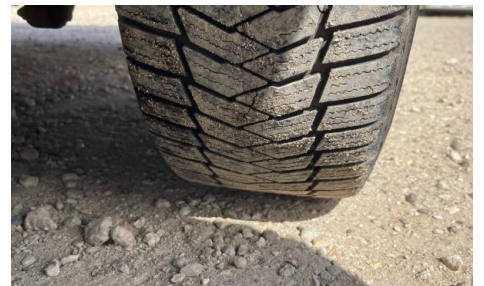

# Condition Check

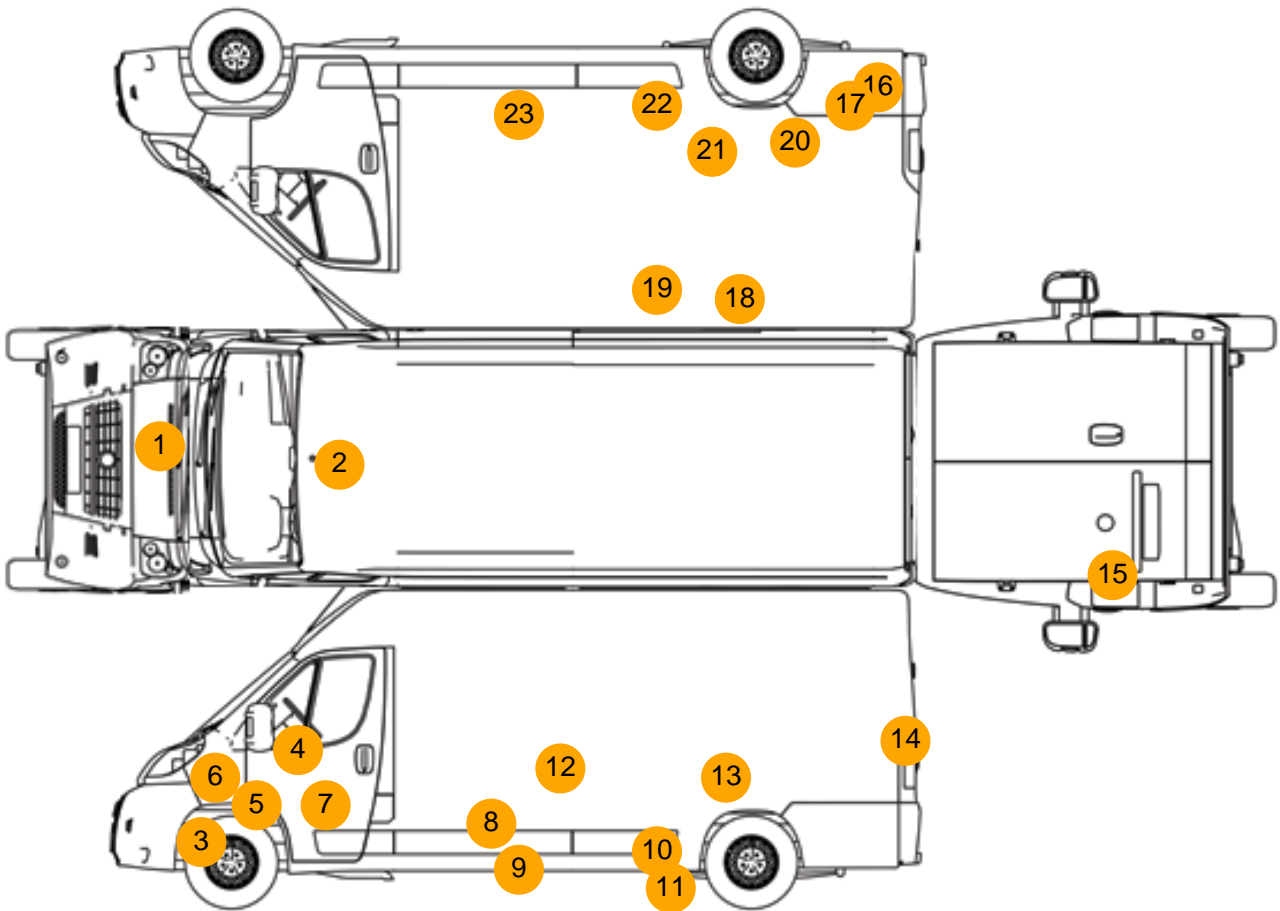

## Damage Photos

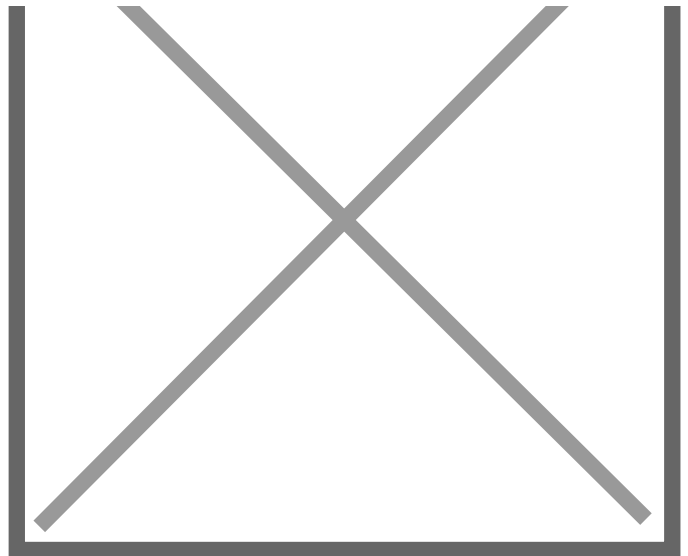
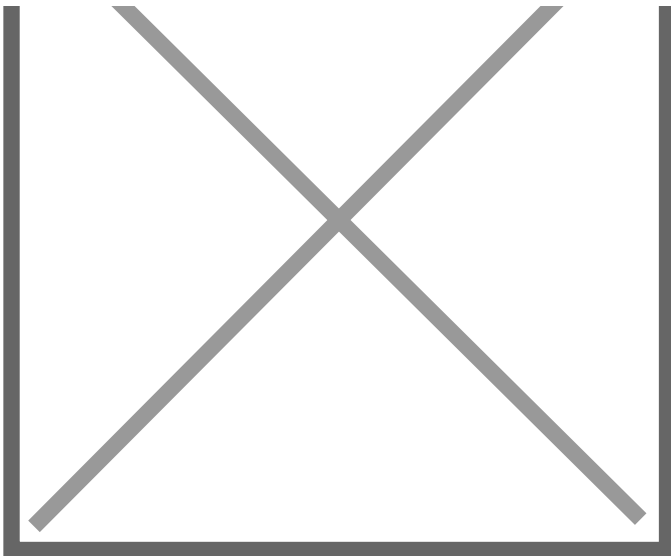

1: Bonnet  
Chipped  
Multiple Chips

2: Panel Front  
Chipped  
Multiple Chips

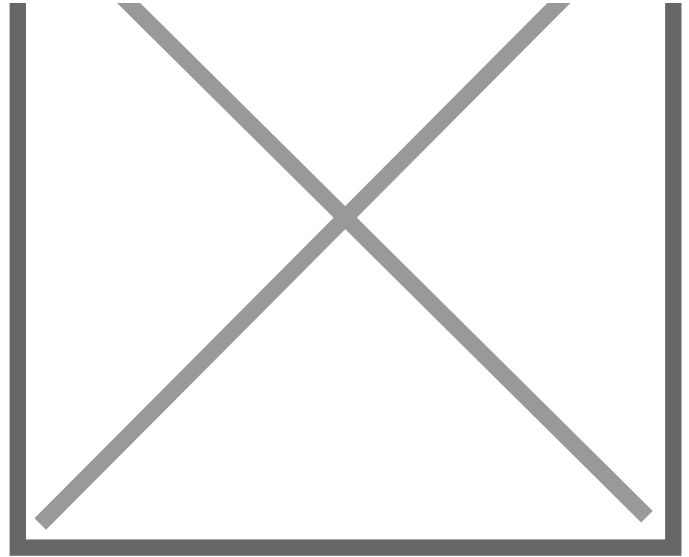
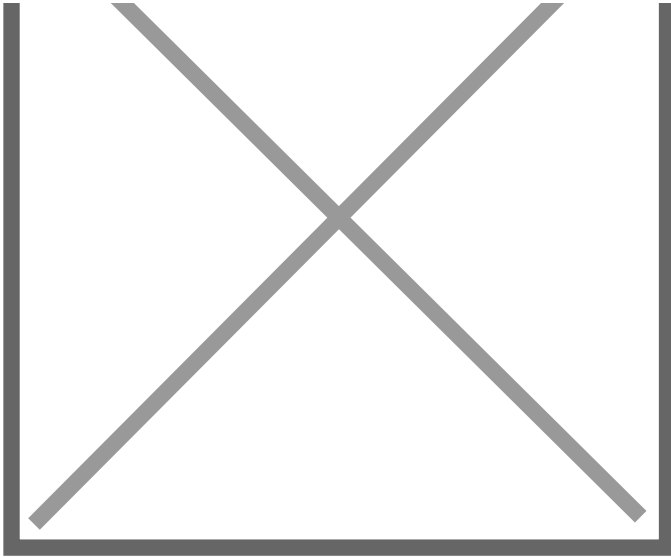

3: Bumper Front Moulding  
Scuffed (Unpainted)  
Over 100mm

4: Door Mirror Assy nsf  
Scuffed (Unpainted)  
Over 100mm

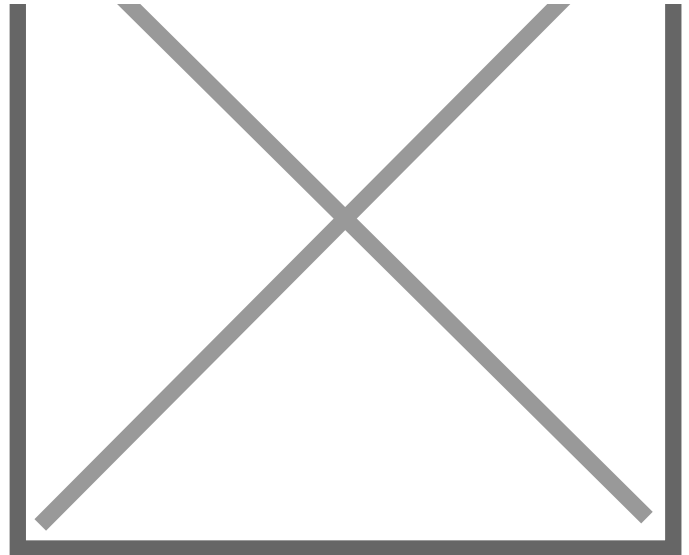
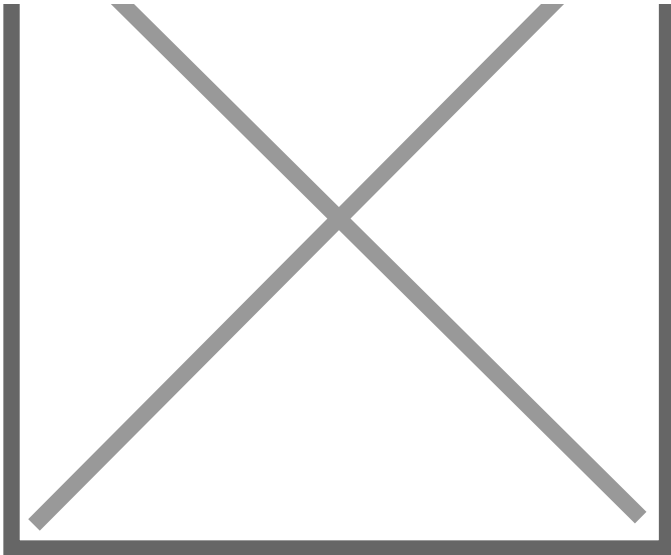

5: Wing nsf  
Dented  
Between 10mm + 30mm

6: Wing nsf  
Dented  
With Paint Damage

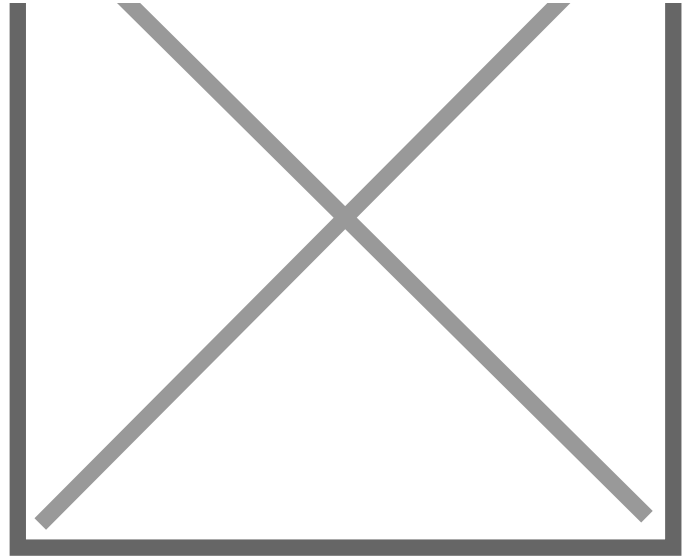
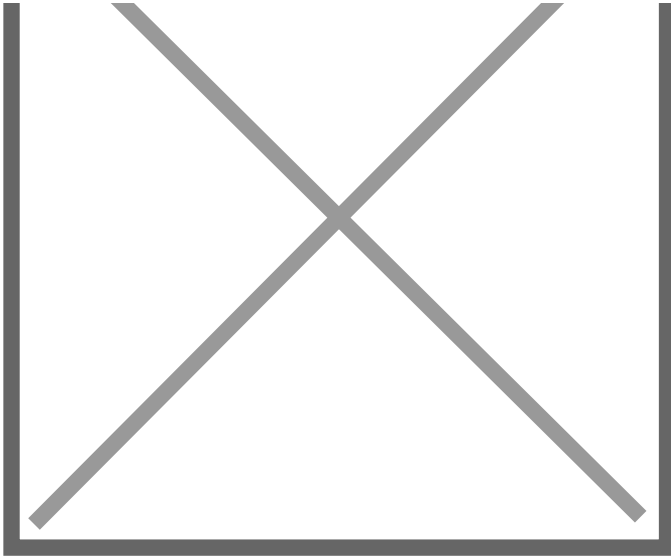

7: Door nsf  
Scratched  
Over 25mm Not Thru Paint

8: Door nsr  
Dented  
With Paint Damage

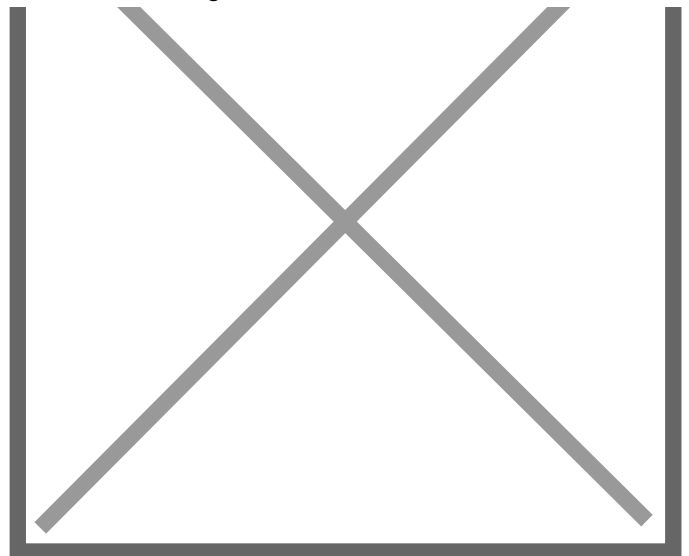
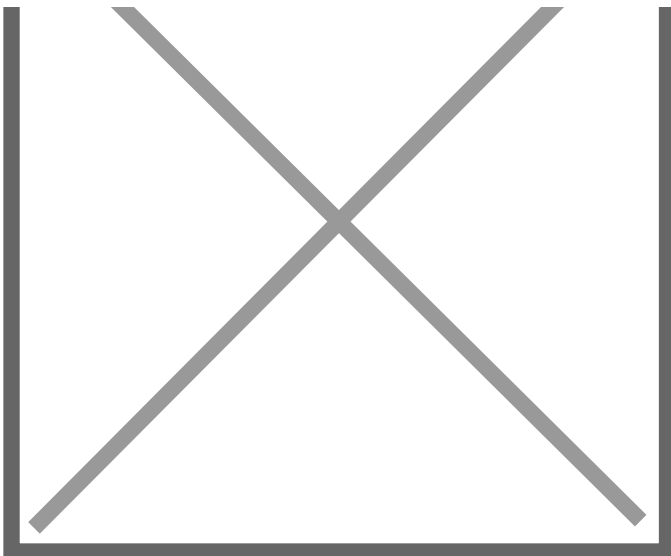

9: Door Moulding nsr  
Scuffed (Unpainted)  
Over 100mm

10: Qtr Panel Moulding ns  
Scuffed (Unpainted)  
Over 100mm

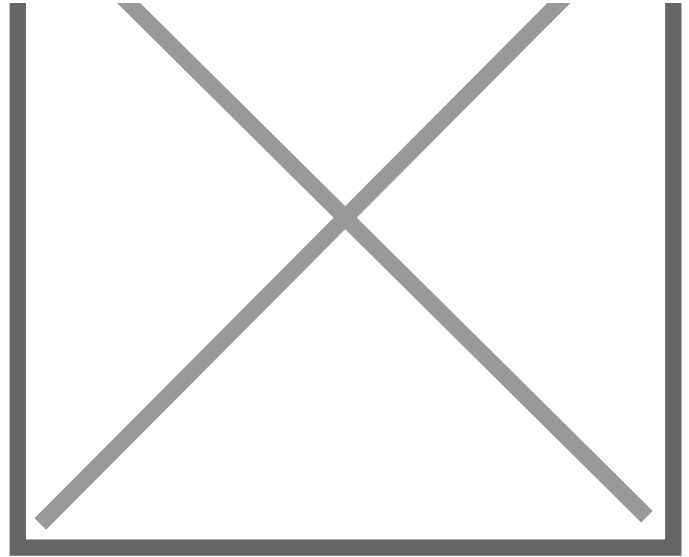
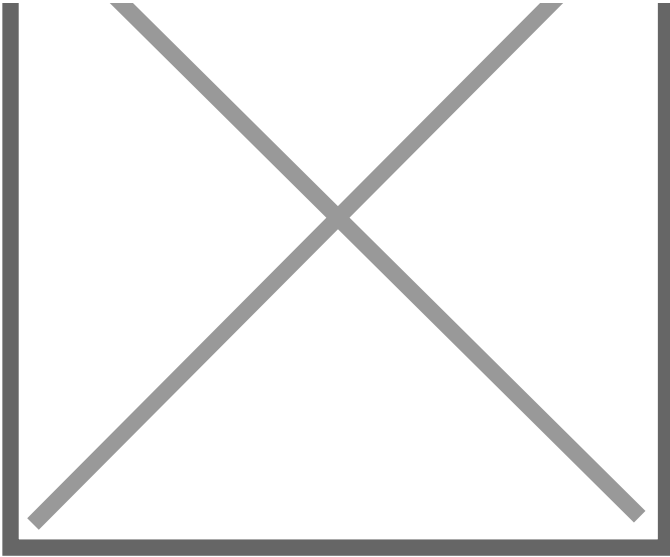

11: Qtr Panel nsr  
Dented  
With Paint Damage

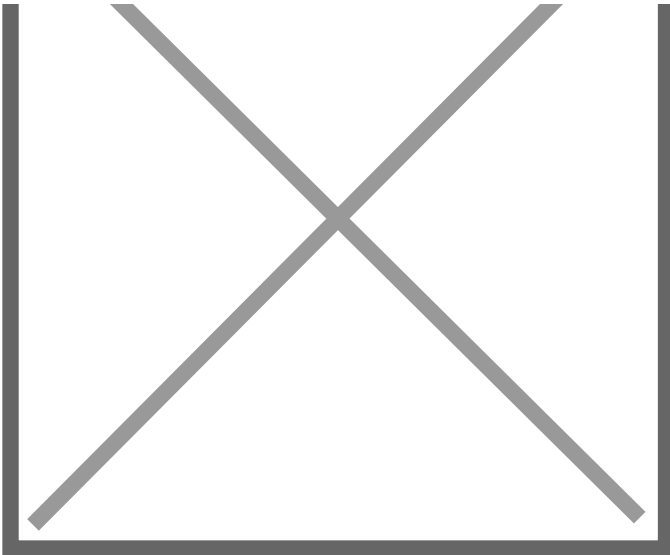

12: Door nsr  
Dented  
Over 30mm

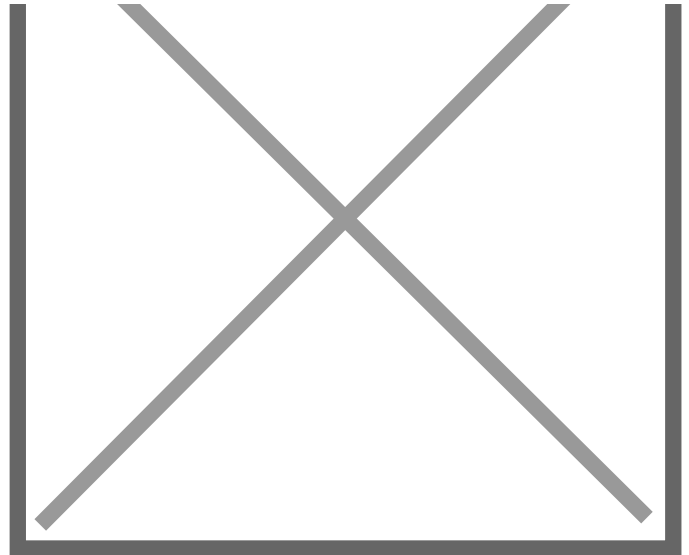

13: Qtr Panel nsr  
Dented  
With Paint Damage

14: Qtr Panel nsr  
Scratched  
Over 25mm Not Thru Paint

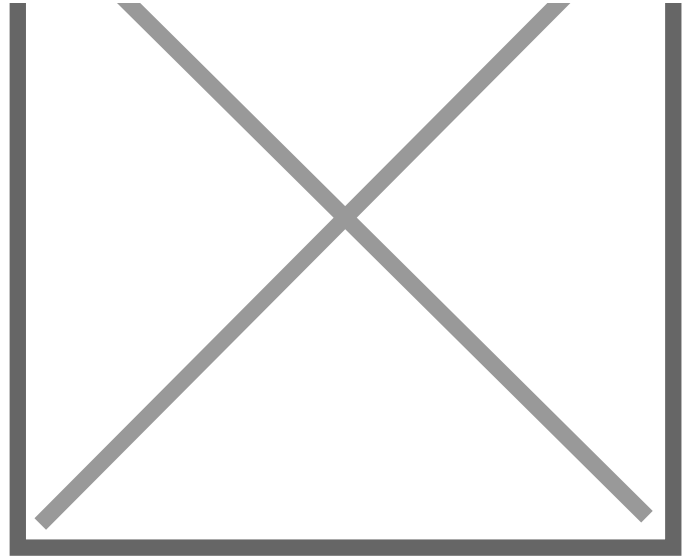
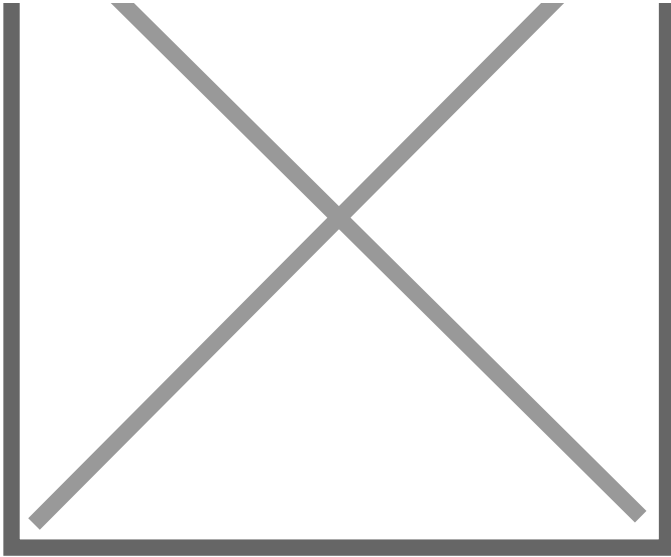

15: Door nsr  
Dented  
With Paint Damage

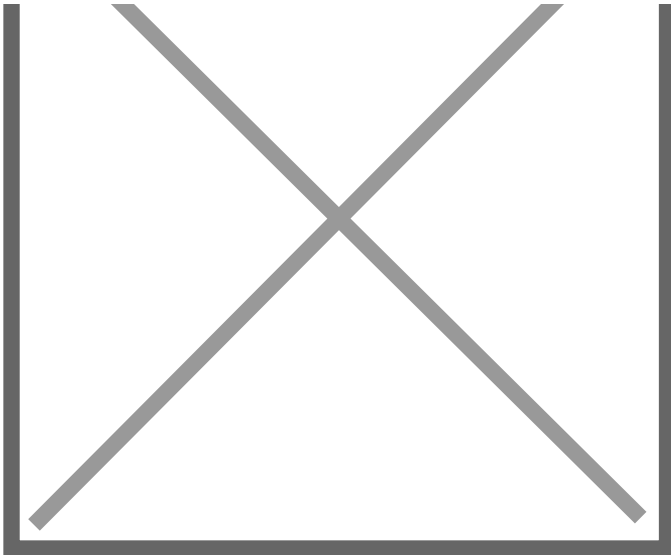

16: Qtr Panel osr  
Dented  
With Paint Damage

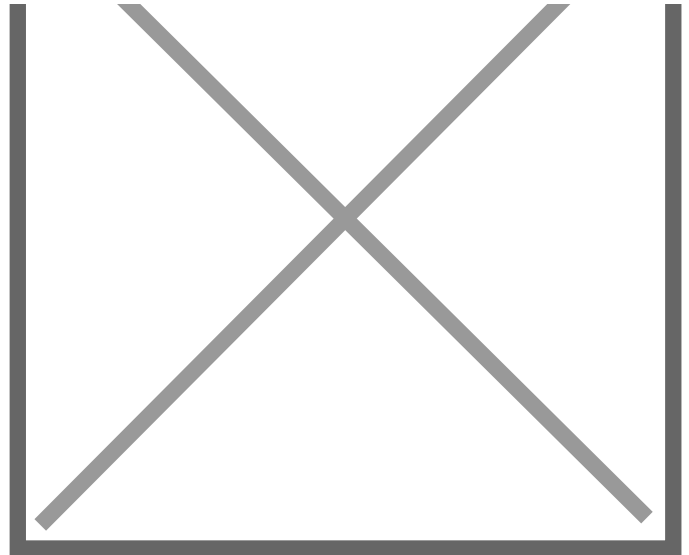

17: Qtr Panel Moulding os  
Broken  
Replace

18: Qtr Panel osr  
Dented  
Between 10mm + 30mm

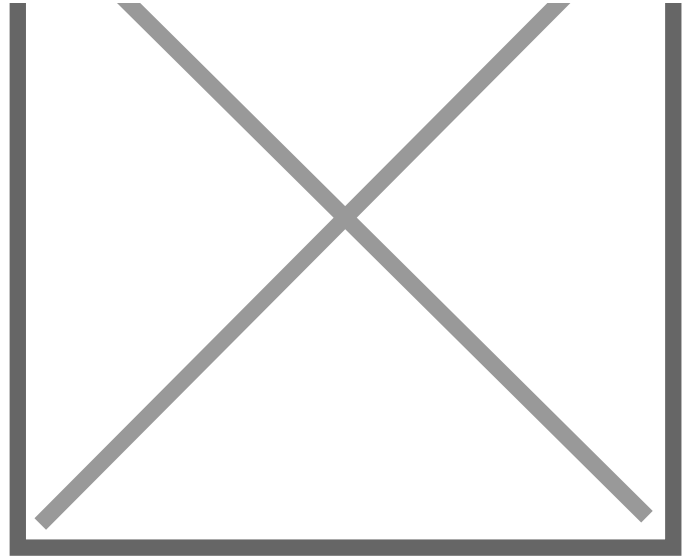
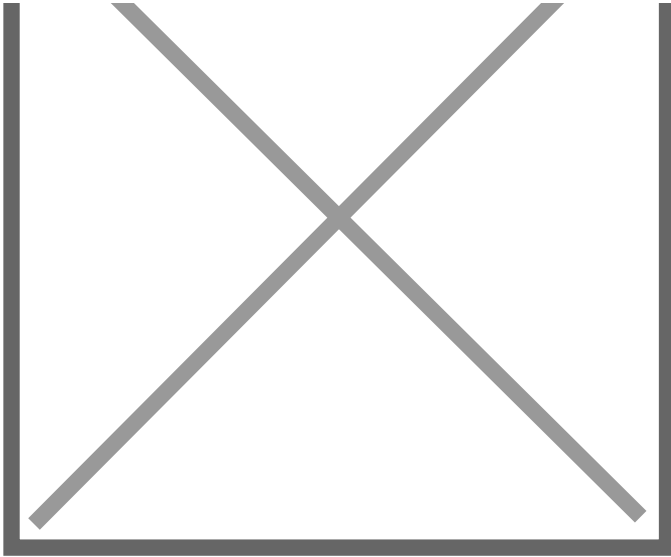

19: Qtr Panel osr  
Scratched  
Over 25mm Not Thru Paint

20: Qtr Panel osr  
Dented  
With Paint Damage

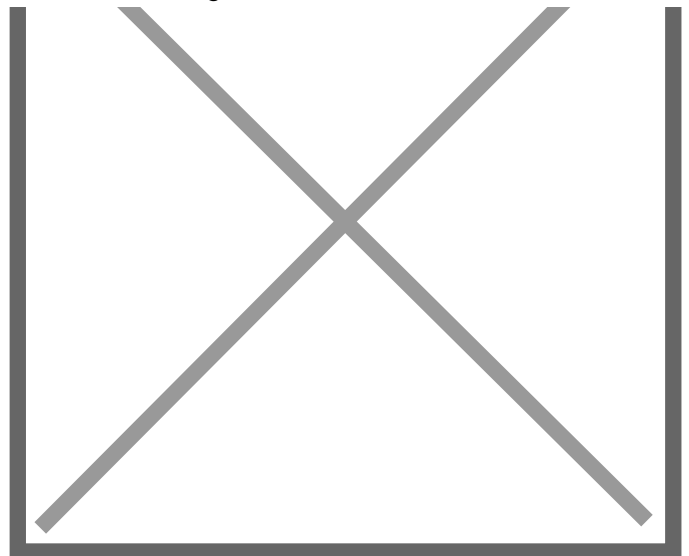
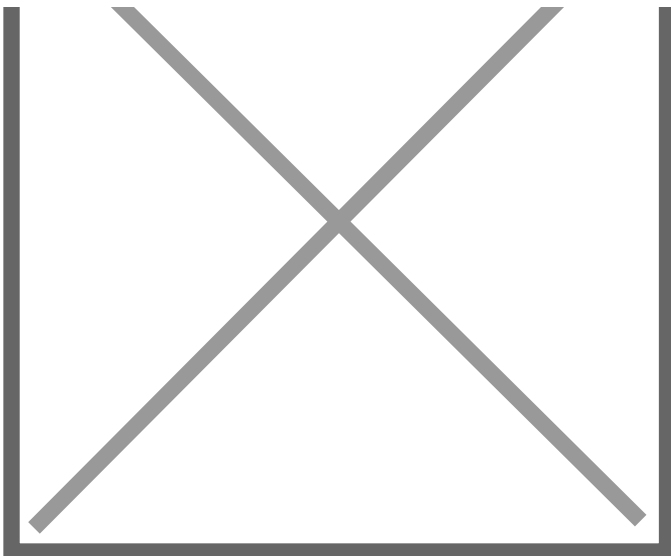

21: Qtr Panel osr  
Scratched  
Over 25mm Thru Paint

22: Qtr Panel Moulding os  
Scuffed (Unpainted)  
Over 100mm

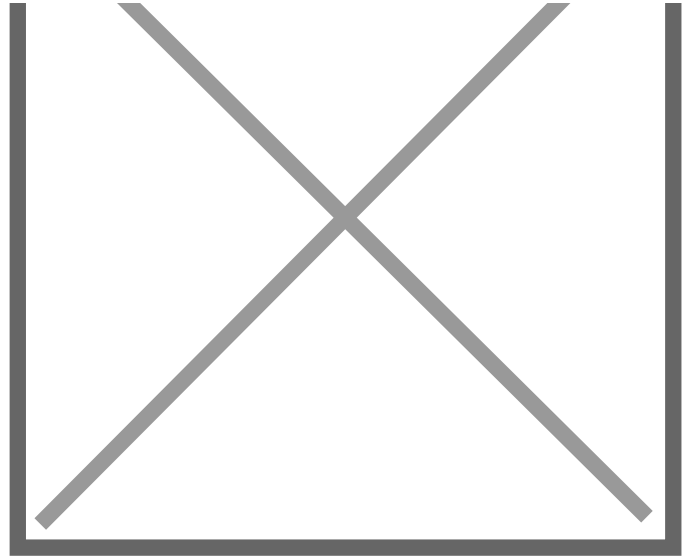
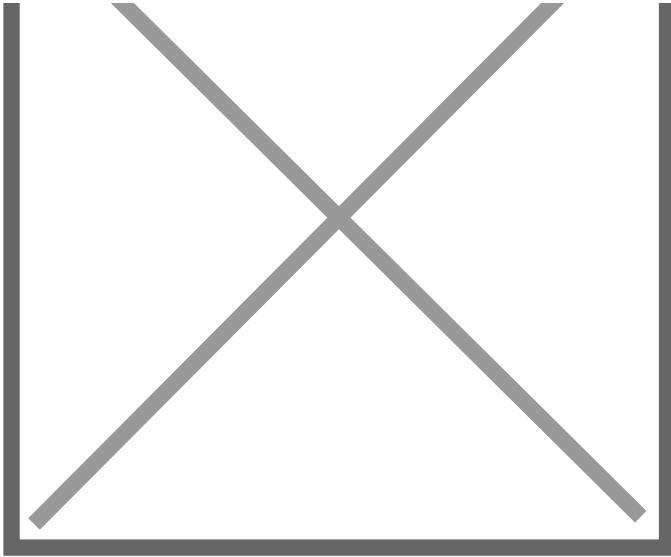

23: Qtr Panel Moulding os  
Scuffed (Unpainted)  
Over 100mm

24: Seat Base Cover osf  
Holed  
Over 3mm

**Interior**

<b>Carpet Condition</b>	Average		<b>Upholstery Condition</b>	Average
<b>Seat Condition</b>	Average		<b>Odour</b>	No
Engine Runs		OK	Gearbox 1st and Reverse Test	OK
Brakes		OK	Clutch Slip Test from Static	OK
Parking Brake		OK	Gearbox Static Gear Selection (engine running)	OK
			No Excessive Smoking	OK
EML light illuminated		OK	Oil warning light illuminated	OK
Airbag light illuminated		OK	DPF light illuminated	OK
ABS light illuminated		OK	Service indicator light illuminated	OK