



COMMERCIAL VEHICLE AUCTIONS LTD
THE UK'S MOST ESTABLISHED COMMERCIAL VEHICLE AUCTIONEERS

Carr Hill Industrial Estate
Doncaster
DN4 8DE

01302 732600 | cva.noreply@cva-auctions.co.uk

VEHICLE INSPECTION REPORT

SP63HYX

Ford Transit T300 2.2 TDCi 100PS

Inspection		Vehicle	
Serious Damage?	No	VAT	Plus VAT
		V5	Buyer To Apply

Details

Reg. date	24/09/2013	VIN	WFOXXTTFXDP39653	CAP Average	£930.00
Year	2013	Body Style	Panel Van MWB	CAP Below	£625.00
Mileage	124,308 Miles Not Warranted	Service history	Part	Gearbox	MANUAL
Fuel Type	Diesel	Service documents	Printout	Gears	6
GVW	3025kg	MOT Due	27/09/2026		
Colour	WHITE	CAP Clean	£1,175.00		

SEVERE ENGINE KNOCK, NO ACCESS TO REAR SIDE LOAD DOOR, ROOF RACK,

Tyres

NSF
NSR
OSF
OSR
Spare

Features

- Digital radio
- Front electric windows

Photos



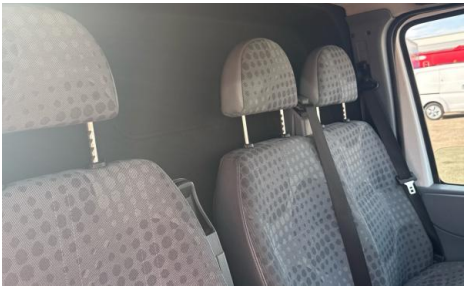

Condition Check

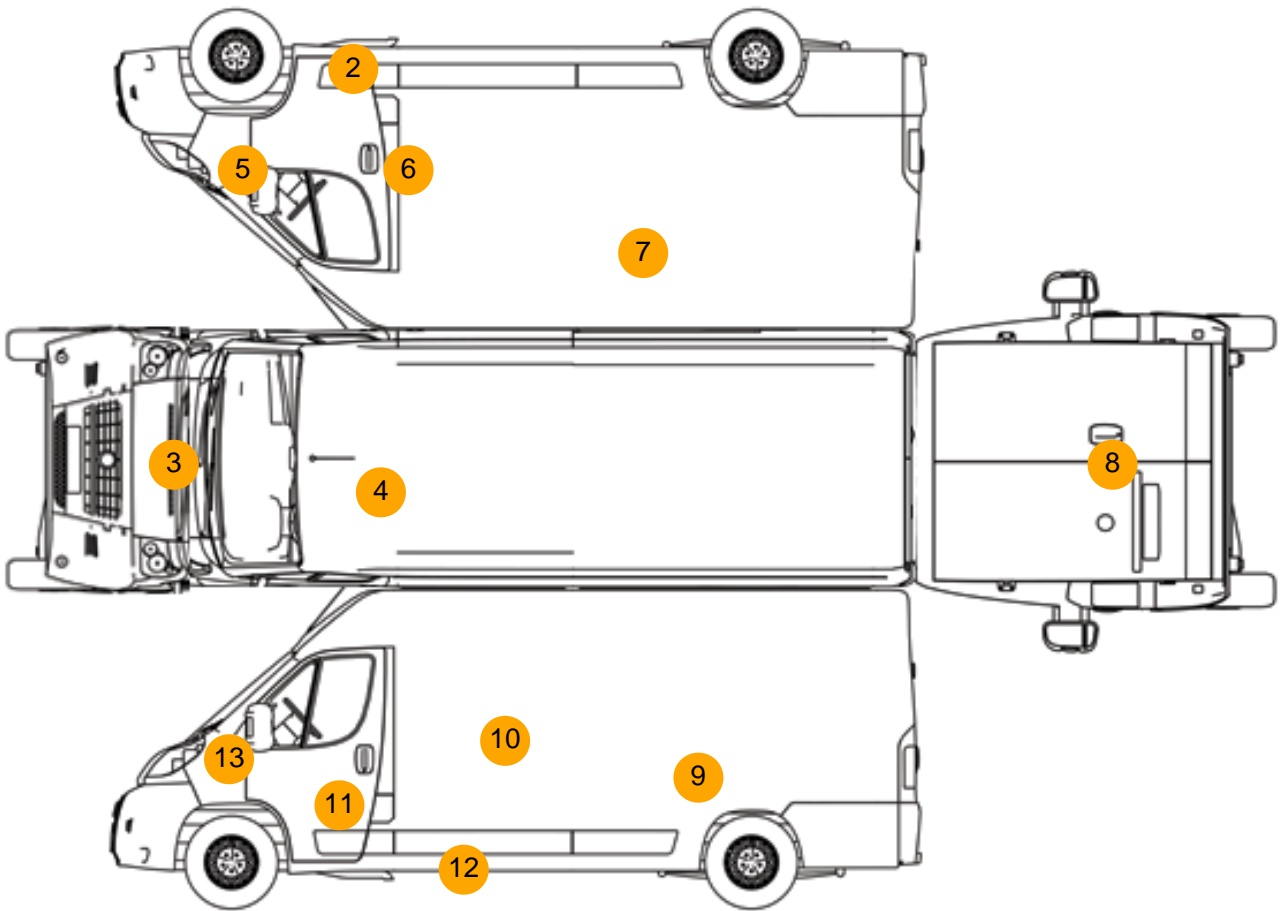

Damage Photos

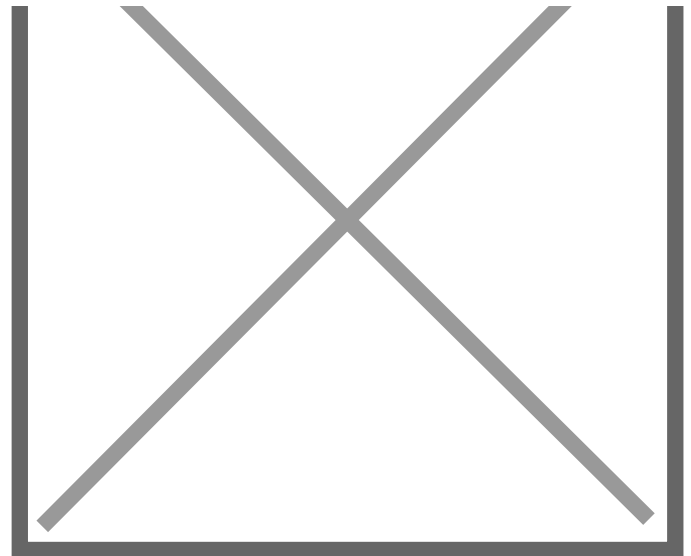
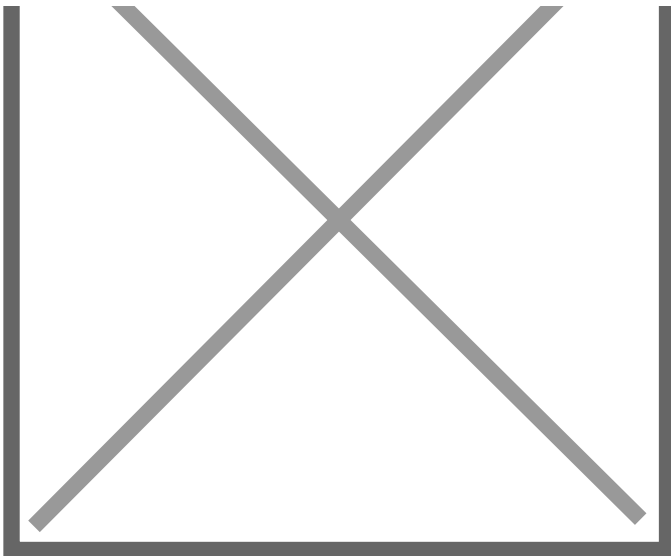

1: Carpets Front
Torn
Over 10mm

2: Sill os
Rusted
Over 5mm

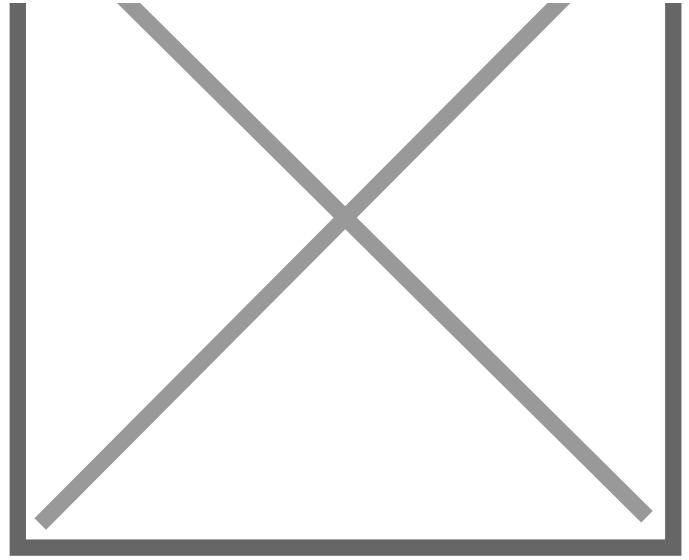
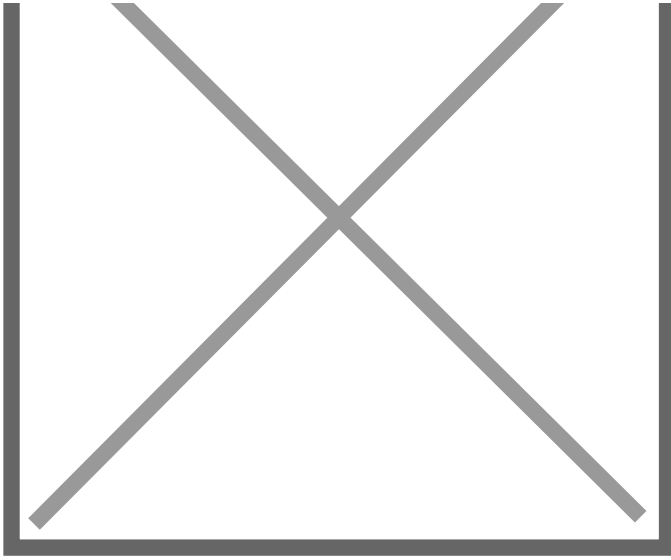

3: Bonnet
Rusted
Over 5mm

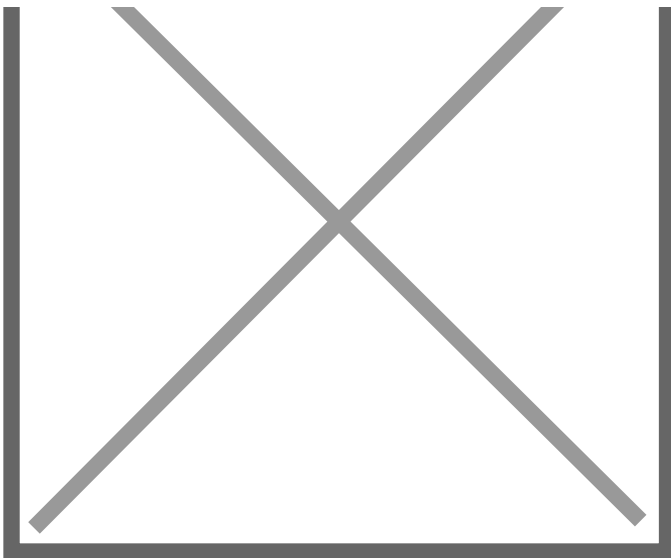

4: Roof
Rusted
Over 5mm

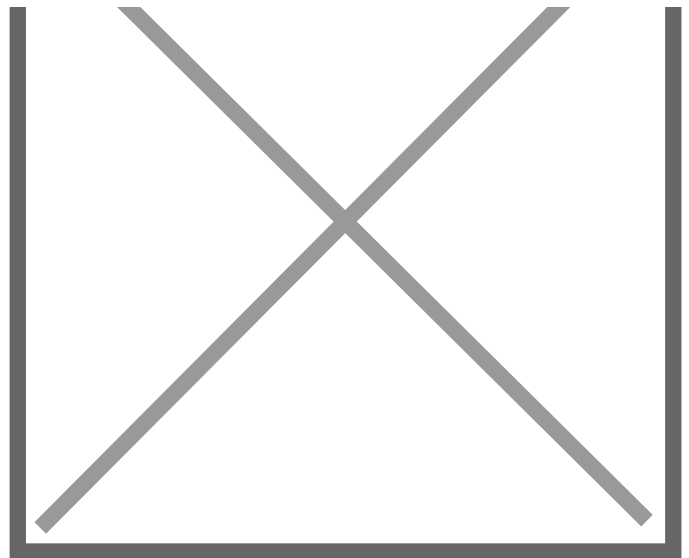

5: Wing osf
Rusted
Over 5mm

6: Door osf
Rusted
Over 5mm

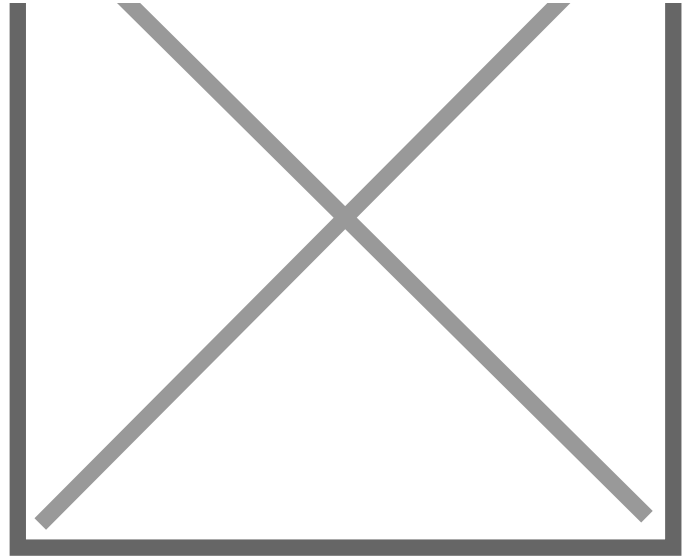
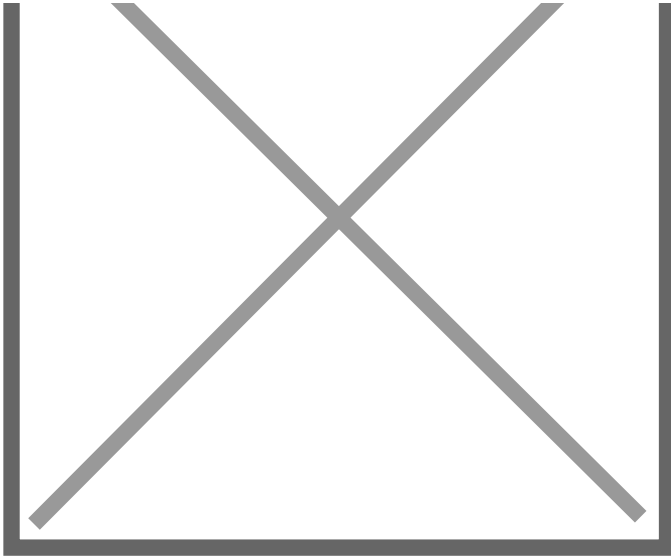

7: Qtr Panel osr
Rusted
Over 5mm

8: Tailgate
Dented
With Paint Damage

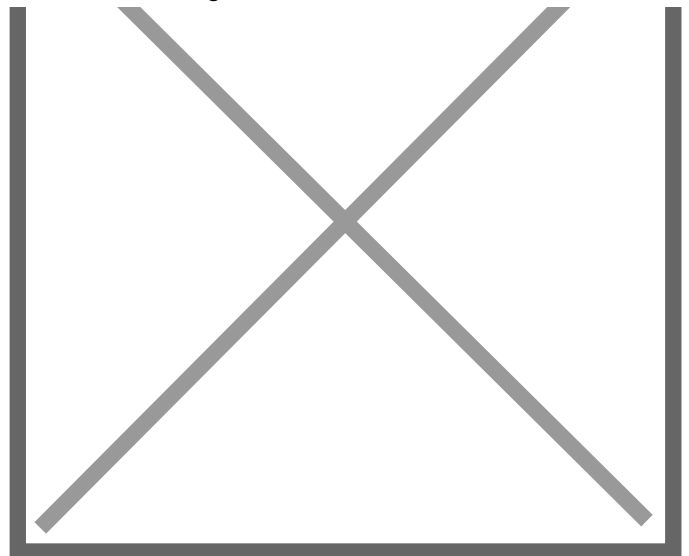
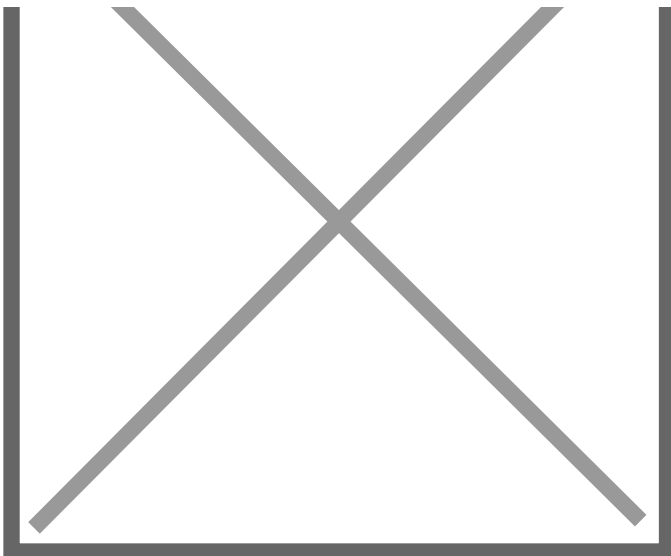

9: Qtr Panel nsr
Rusted
Over 5mm

10: Door nsr
Dented
With Paint Damage

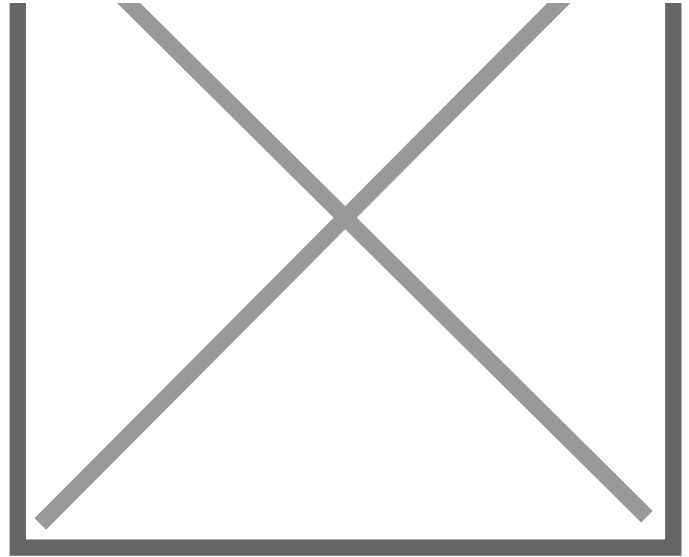
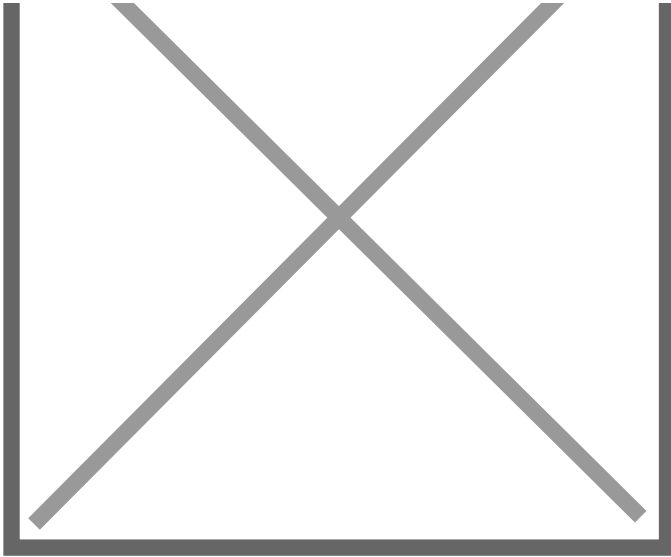

11: Door nsf
Dented
With Paint Damage

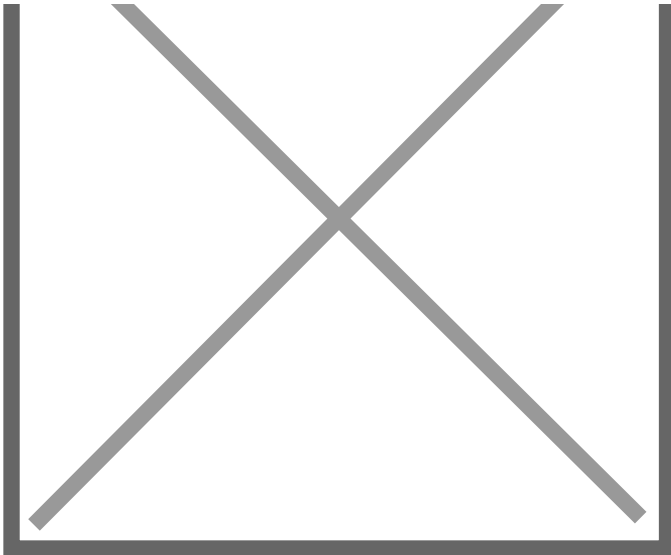

12: Sill ns
Rusted
Over 5mm

13: Wing nsf
Dented
Over 30mm

Interior

Carpet Condition
Seat Condition

Average
Average

Upholstery Condition
Odour

Average
No

Engine Runs	OK	Gearbox 1st and Reverse Test	OK
Brakes	OK	Clutch Slip Test from Static	OK
Turbo Boosting	OK	Gearbox Static Gear Selection (engine running)	OK
Parking Brake	OK	No Excessive Smoking	OK

EML light illuminated	OK	Oil warning light illuminated	OK
Airbag light illuminated	OK	DPF light illuminated	OK
ABS light illuminated	OK	Service indicator light illuminated	OK
Windows	OK	Radio	OK
		Steering	OK