



COMMERCIAL VEHICLE AUCTIONS LTD
THE UK'S MOST ESTABLISHED COMMERCIAL VEHICLE AUCTIONEERS

Carr Hill Industrial Estate
Doncaster
DN4 8DE

01302 732600 | cva.noreply@cva-auctions.co.uk

VEHICLE INSPECTION REPORT

BN61MXR

Volvo B9TL WRIGHTBUS ECLIPSE GEMINI 2

Non Runner

Inspection		Vehicle	
Serious Damage?	No	VAT	Plus VAT
		V5	Buyer To Apply

Details					
Reg. date	22/12/2011	Colour	RED/CREAM	Gearbox	AUTOMATIC
Year	2011	VIN	YV3S4R120CA153835	Axle Combi	4x2
Mileage	Not Showing	Body Style	Bus	Rear Suspension	Air
Fuel Type	Diesel	MOT Due	04/09/2026		
GVW	18000kg	Cab Type	DAY CAB		

5% BUYERS FEE *NON-RUNNER, TURNS OVER DOES NOT START* 73 SEATS, 17 STANDING, 1 WHEELCHAIR, MOT SHOWS 373,059 MILES 05/09/2025

Tyres				
NSF	NSI1	NSI2	NSI3	NSI4
OSF	OSI1	OSI2	OSI3	OSI4
Spare	NSO1	NSO2	NSO3	NSO4
	OSO1	OSO2	OSO3	OSO4

Features

- Park assist camera

Photos



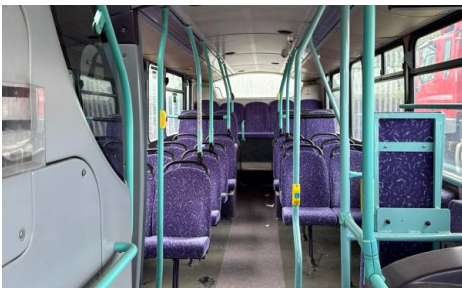
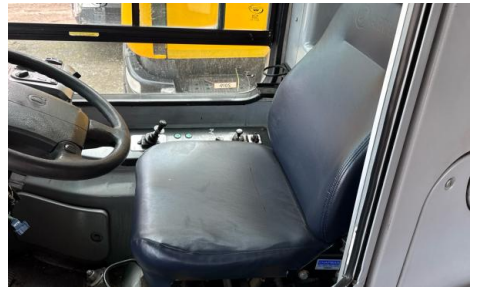

UPPER	43				
LOWER	30	OR	27	OR	27
STANDING	17				
WHEELCHAIRS	0		0		1

Condition Check

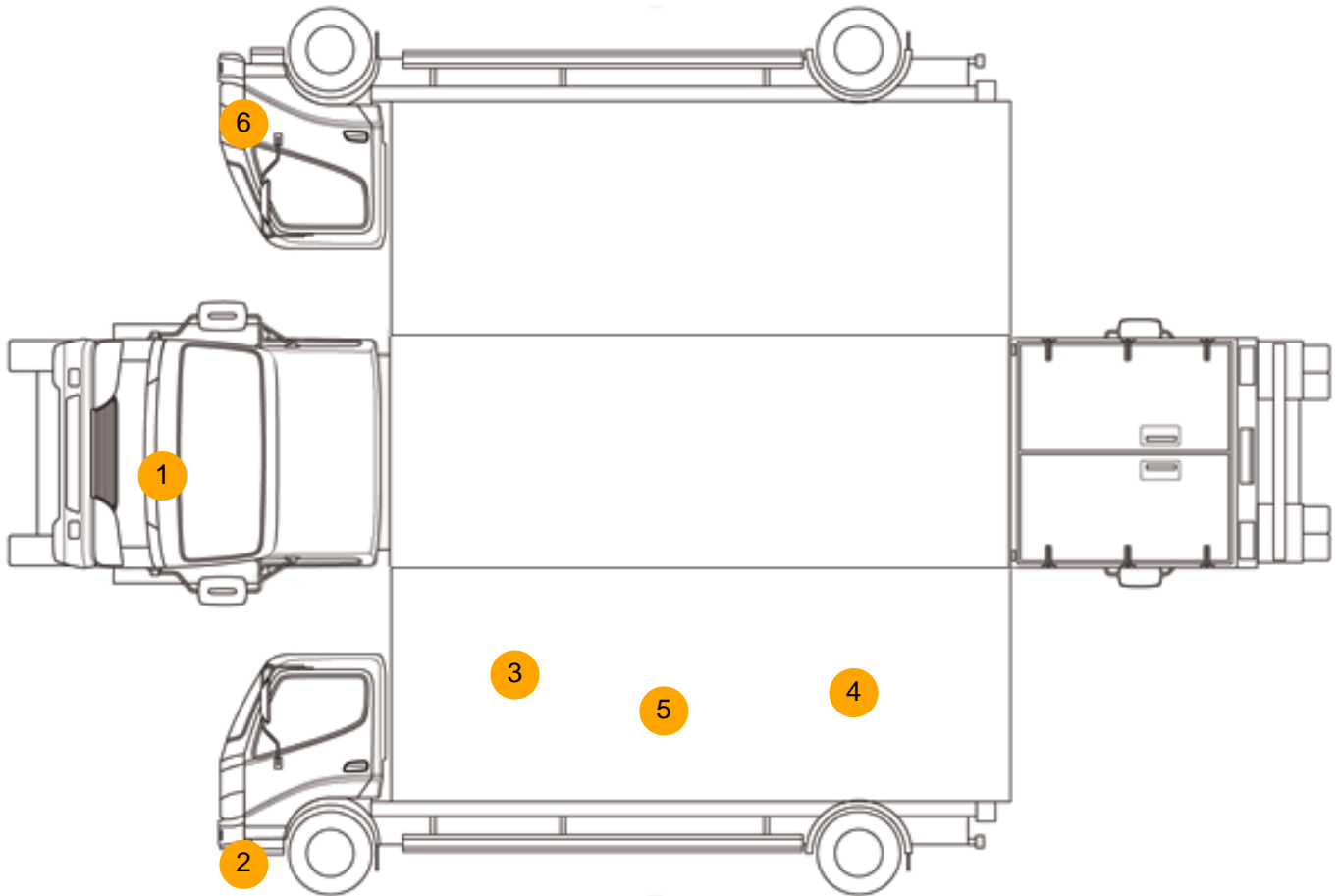

Damage Photos



1: Bonnet
Chipped
Multiple Chips

2: Bumper Front
Scratched
Over 100mm Thru Paint



3: Qtr Panel nsr
Scratched
Over 25mm Thru Paint

4: Qtr Panel nsr
Scratched
Over 25mm Thru Paint



5: Aperture Seal nsr
Broken
Replace

6: Panel Front
Scratched
Over 25mm Thru Paint



7: Fascia Panel
Missing
Replace

Interior

Carpet Condition
Seat Condition

OK
OK

Upholstery Condition
Odour

Poor
-

Engine Runs

Fault