



COMMERCIAL VEHICLE AUCTIONS LTD
THE UK'S MOST ESTABLISHED COMMERCIAL VEHICLE AUCTIONEERS

Carr Hill Industrial Estate
Doncaster
DN4 8DE

01302 732600 | cva.noreply@cva-auctions.co.uk

VEHICLE INSPECTION REPORT

YF18FRO

Ford Transit 350 2.0 TDCI 170PS

Inspection		Vehicle	
Serious Damage?	No	VAT	Plus VAT
		V5	Present

Details

Reg. date	16/07/2018	Colour	WHITE	CAP Average	£5,225.00
Year	2018	VIN	WFOXXXTTGXJJ11430	CAP Below	£3,975.00
Mileage	81,881 Miles Warranted	Body Style	Panel Van L2	Gearbox	MANUAL
Fuel Type	Diesel	MOT Due	15/07/2026	Gears	6
GVW	3500kg	CAP Clean	£6,150.00		

AD-BLUE, SIDE LOADING DOOR, E/MIRRORS

Tyres

NSF
NSR
OSF
OSR
Spare

Features

- Front parking sensor
- Park assist camera
- Rear parking sensor
- Front electric windows

Photos



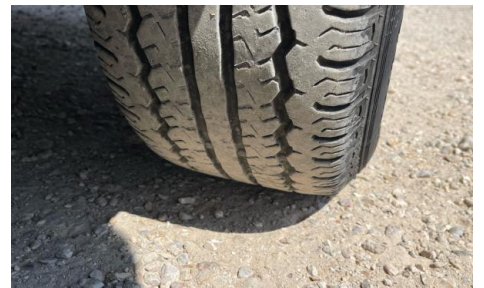
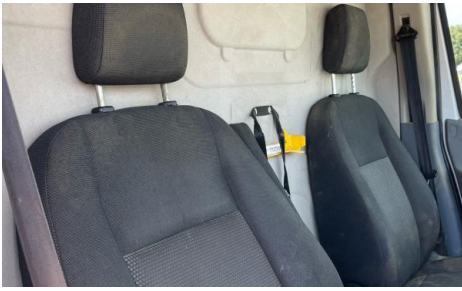

Condition Check

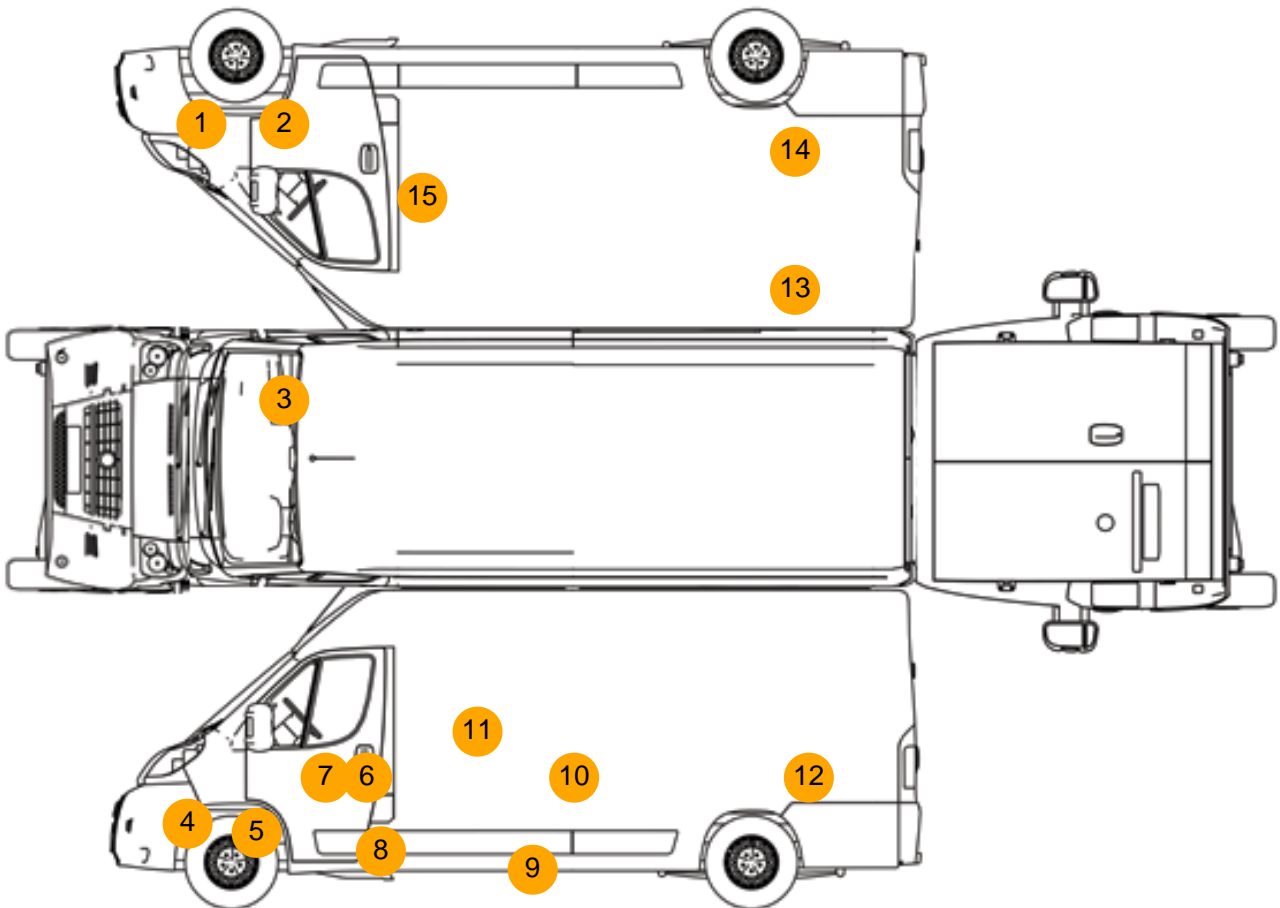

Damage Photos



1: Bumper Front Moulding
Scuffed (Unpainted)
Over 100mm

2: Wing Front Arch Extension os
Scuffed (Unpainted)
UpTo 100mm



3: Screen Front
Chipped
Over 10mm

4: Bumper Front Moulding
Scuffed (Unpainted)
Over 100mm



5: Wing Front Arch Extension ns
Scuffed (Unpainted)
UpTo 100mm

6: Door nsf
Scratched
Over 25mm Not Thru Paint



7: Door nsf
Dented
Between 10mm + 30mm

8: Door Moulding nsf
Scuffed (Unpainted)
Over 100mm



9: Door Moulding nsr
Scuffed (Unpainted)
Over 100mm

10: Door nsr
Dented
Over 30% Of Panel



11: Door nsr
Dented
Between 10mm + 30mm

12: Qtr Panel nsr
Scratched
Over 25mm Not Thru Paint



13: Qtr Panel osr
Scratched
Over 25mm Not Thru Paint

14: Qtr Panel osr
Scratched
Over 25mm Not Thru Paint



15: Door osf
Chipped
Edge Chip

16: Seat Base Cover osf
Holed
Over 3mm

Interior

Carpet Condition	Average	Upholstery Condition	Average
Seat Condition	Average	Odour	No
Engine Runs	OK	Gearbox 1st and Reverse Test	OK
Brakes	OK	Clutch Slip Test from Static	OK
Parking Brake	OK	Gearbox Static Gear Selection (engine running)	OK
		No Excessive Smoking	OK
EML light illuminated	OK	Oil warning light illuminated	OK
Airbag light illuminated	OK	DPF light illuminated	OK
ABS light illuminated	OK	Service indicator light illuminated	OK