



COMMERCIAL VEHICLE AUCTIONS LTD
THE UK'S MOST ESTABLISHED COMMERCIAL VEHICLE AUCTIONEERS

Carr Hill Industrial Estate
Doncaster
DN4 8DE

01302 732600 | cva.noreply@cva-auctions.co.uk

VEHICLE INSPECTION REPORT

PJ20ZGA

Mercedes-Benz Sprinter 314 CDI

Inspection		Vehicle	
Serious Damage?	No	VAT	Plus VAT
		V5	To Follow

Details					
Reg. date	07/08/2020	Colour	WHITE	CAP Average	£6,775.00
Year	2020	VIN	W1V9076352P254362	CAP Below	£5,400.00
Mileage	166,782 Miles Warranted	Body Style	Panel Van L3	Gearbox	AUTOMATIC
Fuel Type	Diesel	MOT Due	04/05/2027	Gears	6
GVW	3500kg	CAP Clean	£7,675.00		

AD-BLUE, SIDE LOADING DOOR

Tyres
NSF
NSR
OSF
OSR
Spare

Features

- Rear parking sensor
- Front electric windows

Photos



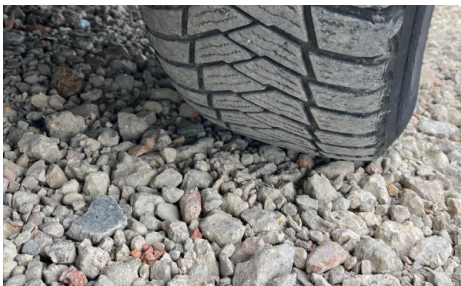
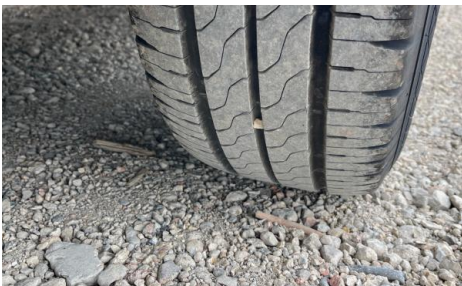
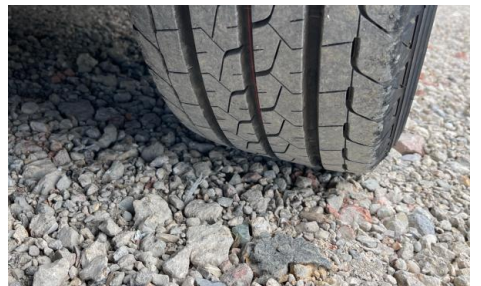
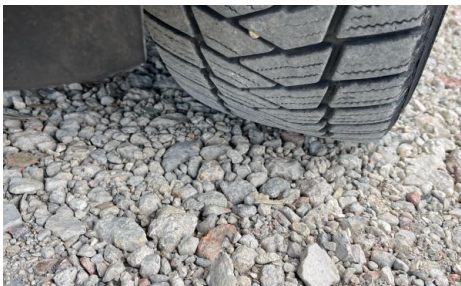
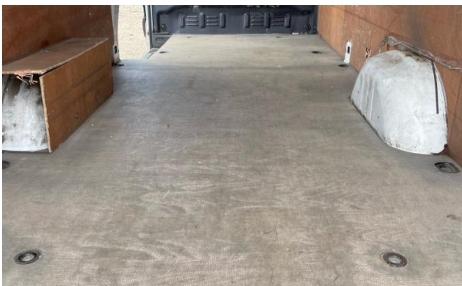

Condition Check

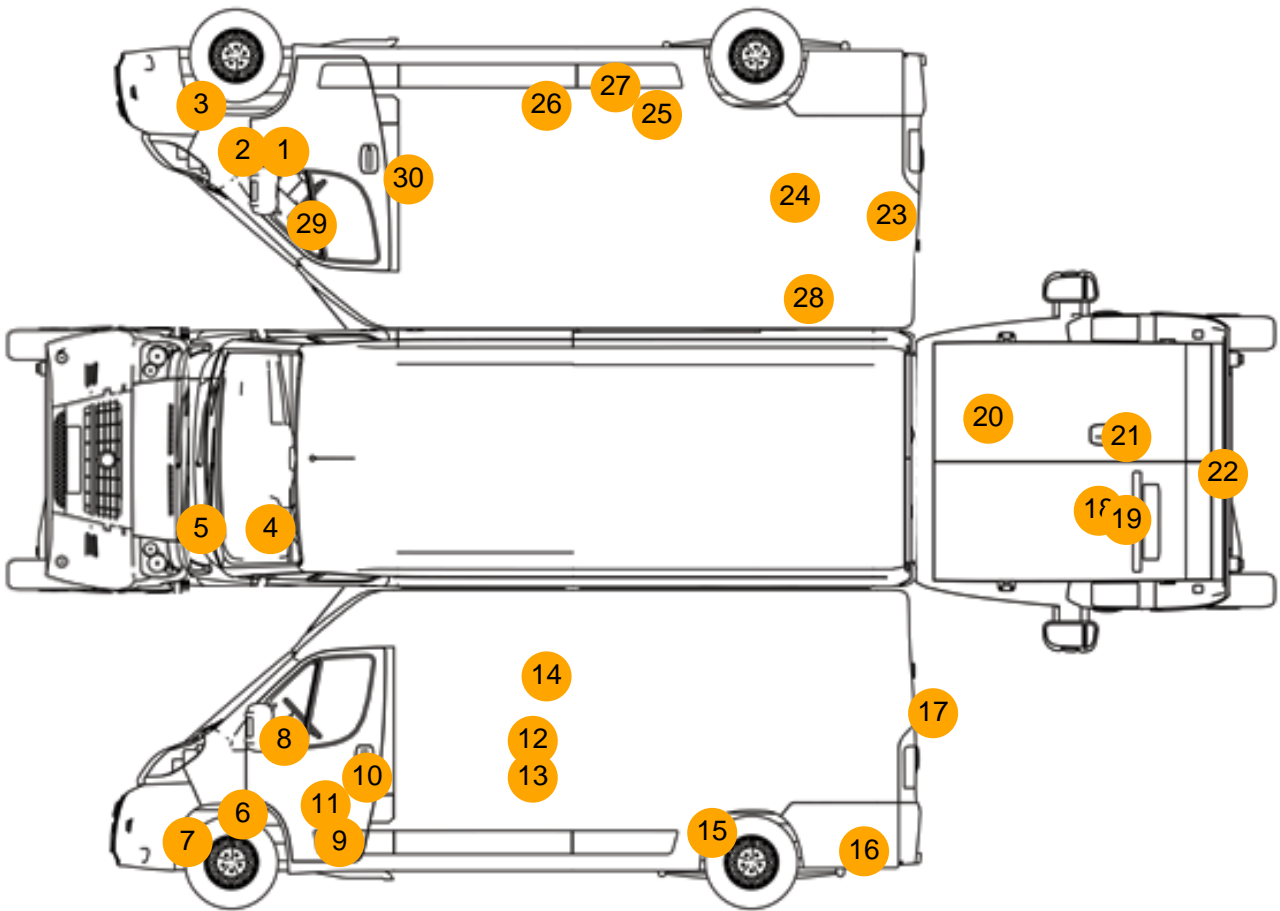

Damage Photos



1: Wing of
Scratched
Over 25mm Not Thru Paint



2: Wing of
Scratched
Over 25mm Not Thru Paint



3: Bumper Front Moulding
Scuffed (Unpainted)
UpTo 100mm

4: Screen Front
Chipped
Over 10mm



5: Bonnet
Scratched
Over 25mm Not Thru Paint

6: Wing nsf
Dented
With Paint Damage



7: Bumper Front Moulding
Scuffed (Unpainted)
UpTo 100mm

8: Door Mirror Assy nsf
Scuffed (Unpainted)
Over 100mm



9: Door nsf
Scratched
Over 25mm Not Thru Paint

10: Door nsf
Dented
Over 2 Up To 10mm

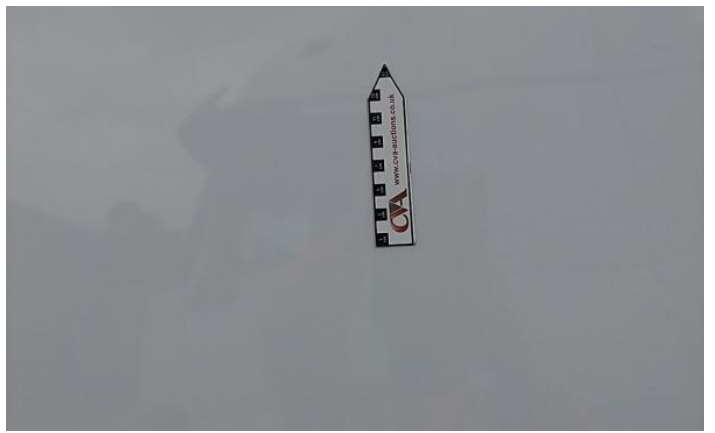

11: Door nsf
Dented
Over 2 Up To 10mm

12: Door nsr
Dented
With Paint Damage



13: Door nsr
Dented
Over 30% Of Panel

14: Door nsr
Dented
With Paint Damage



15: Qtr Panel nsr
Dented
With Paint Damage

16: Qtr Panel nsr
Scratched
Over 25mm Thru Paint



17: Qtr Panel nsr
Dented
With Paint Damage

18: Door nsr
Dented
Between 10mm + 30mm



19: Badgedecal Rear
Missing
Replace

20: Door osr
Dented
Between 10mm + 30mm



21: Door osr
Dented
Over 30mm

22: Door osr
Dented
With Paint Damage



23: Qtr Panel osr
Dented
With Paint Damage

24: Qtr Panel osr
Dented
With Paint Damage



25: Qtr Panel osr
Dented
With Paint Damage

26: Qtr Panel Moulding os
Scuffed (Unpainted)
Over 100mm

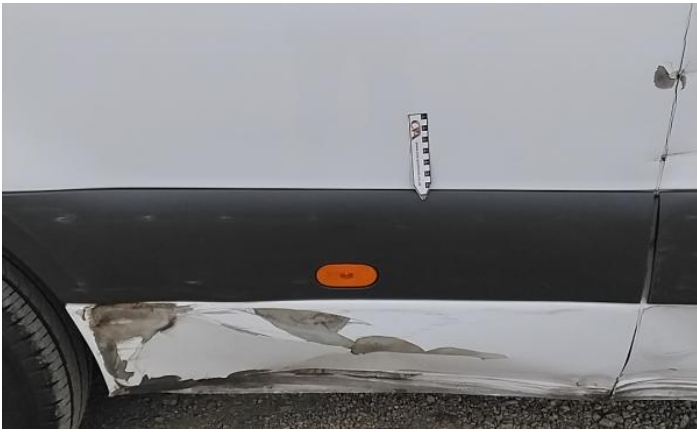

27: Qtr Panel Moulding os
Scuffed (Unpainted)
Over 100mm

28: Qtr Panel osr
Scratched
Over 25mm Not Thru Paint



29: Door Mirror Assy osf
Scuffed (Unpainted)
UpTo 100mm

30: Door osf
Chipped
Edge Chip



31: Seat Base Cover osf
Torn
Over 3mm

Interior

Carpet Condition	Average	Upholstery Condition	Average
Seat Condition	Average	Odour	No
Engine Runs	OK	Gearbox 1st and Reverse Test	OK
Brakes	OK	Clutch Slip Test from Static	OK
Parking Brake	OK	Gearbox Static Gear Selection (engine running)	OK
		No Excessive Smoking	OK
EML light illuminated	OK	Oil warning light illuminated	OK
Airbag light illuminated	OK	DPF light illuminated	OK
ABS light illuminated	OK	Service indicator light illuminated	OK