



COMMERCIAL VEHICLE AUCTIONS LTD
THE UK'S MOST ESTABLISHED COMMERCIAL VEHICLE AUCTIONEERS

Carr Hill Industrial Estate
Doncaster
DN4 8DE

01302 732600 | cva.noreply@cva-auctions.co.uk

VEHICLE INSPECTION REPORT

KX68BPU

Isuzu D-Max

Inspection

Serious Damage? No

Vehicle

VAT Plus VAT

V5 Present

Details

Reg. date 02/10/2018

Year 2018

Mileage 176,358 Miles
Warranted

Fuel Type Diesel

GVW 3500kg

Colour WHITE

VIN MPATFS87JJT003384

Body Style Access Platform

Service history Yes

MOT Due 20/07/2026

Gearbox MANUAL

Gears 6

Axle Combi 4x4

WARNING LIGHTS ON DASH PALFINGER P 130 PLATFORM (YEAR 2018)

Tyres

NSF

NSR

OSF

OSR

Spare

Features

- Park assist camera
- Air conditioning
- Front electric windows

Photos





Condition Check

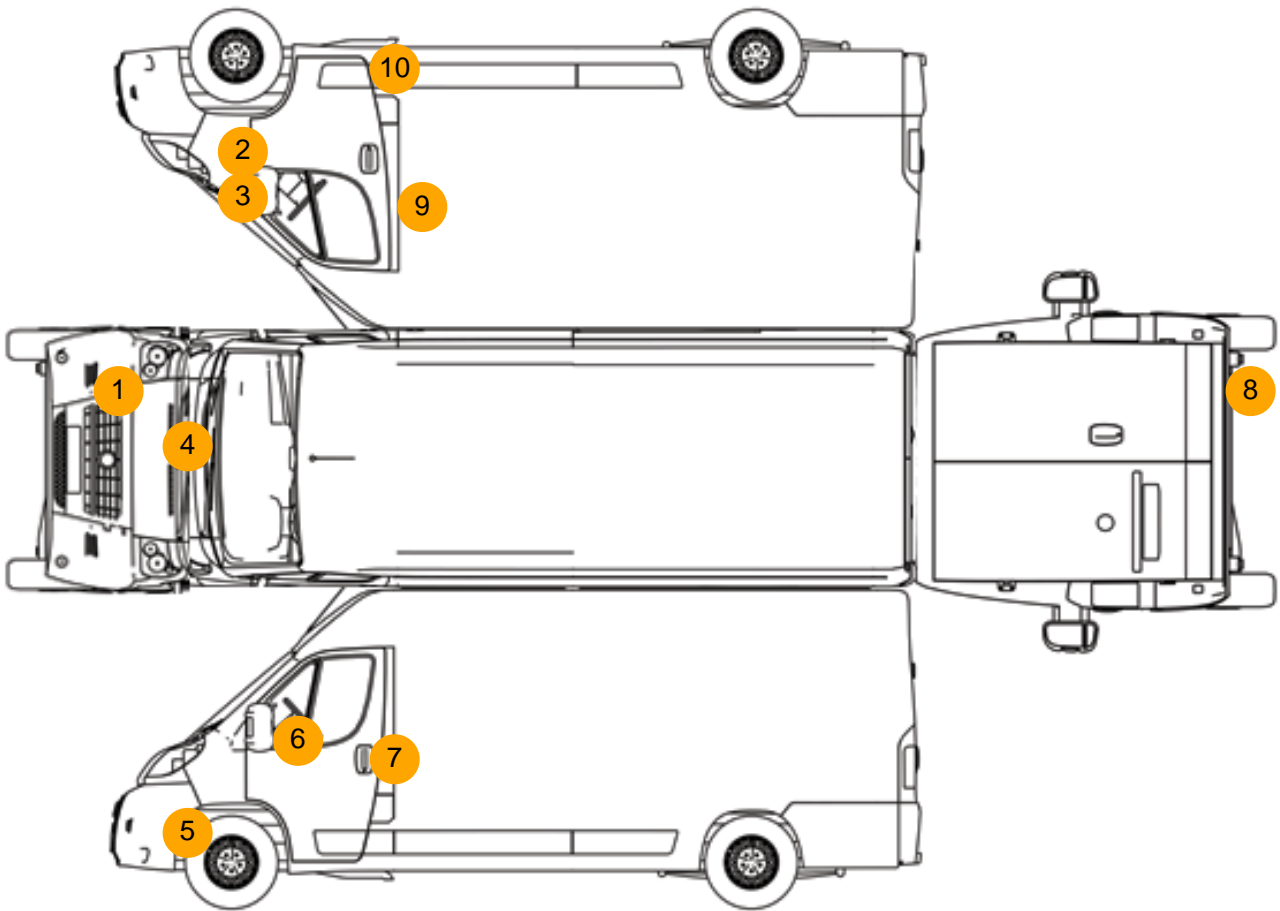

Damage Photos



1: Bumper Front
Dented
Over 30mm



2: Wing of
Dented
Over 30mm



3: Wing osf
Chipped
Multiple Chips

4: Bonnet
Chipped
Multiple Chips



5: Bumper Front Moulding
Scuffed (Unpainted)
Over 100mm

6: Door Mirror Assy nsf
Broken
Replace



7: Door nsf
Chipped
1 To 5

8: Bumper Rear
Hole
UpTo 25mm



9: Door osf
Chipped
Edge Chip

10: Sill os
Dented
With Paint Damage

Interior

Carpet Condition	Average		Upholstery Condition	Average
Seat Condition	Average		Odour	No
Engine Runs		OK	Gearbox 1st and Reverse Test	OK
Brakes		OK	Clutch Slip Test from Static	OK
Parking Brake		OK	Gearbox Static Gear Selection (engine running)	OK
			No Excessive Smoking	OK
EML light illuminated		OK	Oil warning light illuminated	OK
Airbag light illuminated		OK	DPF light illuminated	OK
ABS light illuminated		OK	Service indicator light illuminated	Fault