



COMMERCIAL VEHICLE AUCTIONS LTD
THE UK'S MOST ESTABLISHED COMMERCIAL VEHICLE AUCTIONEERS

Carr Hill Industrial Estate
Doncaster
DN4 8DE

01302 732600 | cva.noreply@cva-auctions.co.uk

VEHICLE INSPECTION REPORT

MV68XYK

Ford Ranger XLT 2.2 TDCI

Inspection		Vehicle	
Serious Damage?	No	VAT	Plus VAT
		V5	To Follow

Details

Reg. date	28/09/2018	Colour	WHITE	CAP Average	£3,975.00
Year	2018	VIN	6FPPXXMJ2PJS65896	CAP Below	£3,000.00
Mileage	192,676 Miles Warranted	Body Style	Pickup Double Cab	Gearbox	MANUAL
Fuel Type	Diesel	MOT Due	09/10/2026	Gears	6
GVW	3200kg	CAP Clean	£4,650.00	Axle Combi	4x4

COLLECTED AS NON-RUNNER - WARNING LIGHT ON DASH, AD BLUE TANK ISSUE - WON'T DRIVE, OUTSTANDING RECALL, ALL TERRAIN TYRES, TWIN SIDE LOAD DOOR, TOW BAR, ROOF RACK, E/MIRRORS, HEATED WINDSCREEN

Tyres

NSF
NSR
OSF
OSR
Spare

Features

- Bluetooth connection
- Radio/CD
- Drivers airbag
- Cruise control
- Air conditioning
- Passenger airbag
- Park assist camera
- Front electric windows
- Central locking
- Digital radio
- Rear electric windows
- Cloth seat trim

Photos



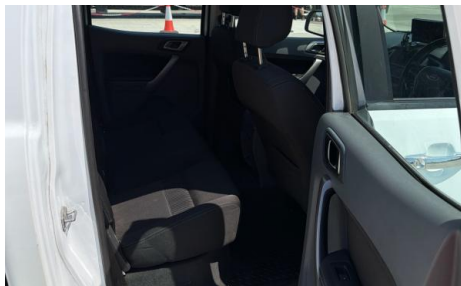
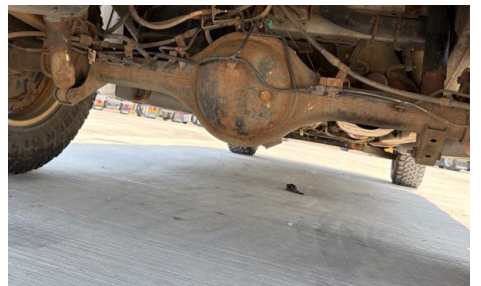
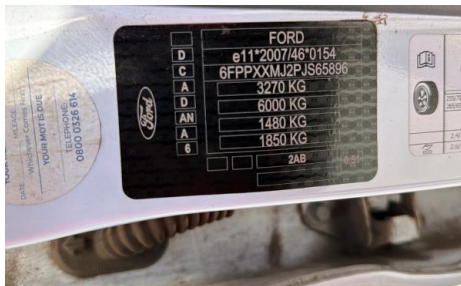
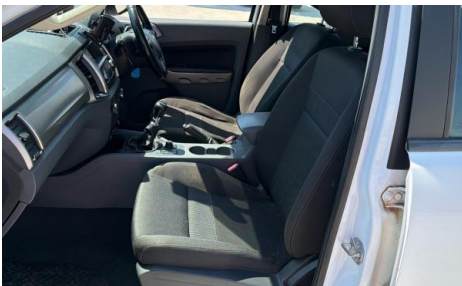

Condition Check

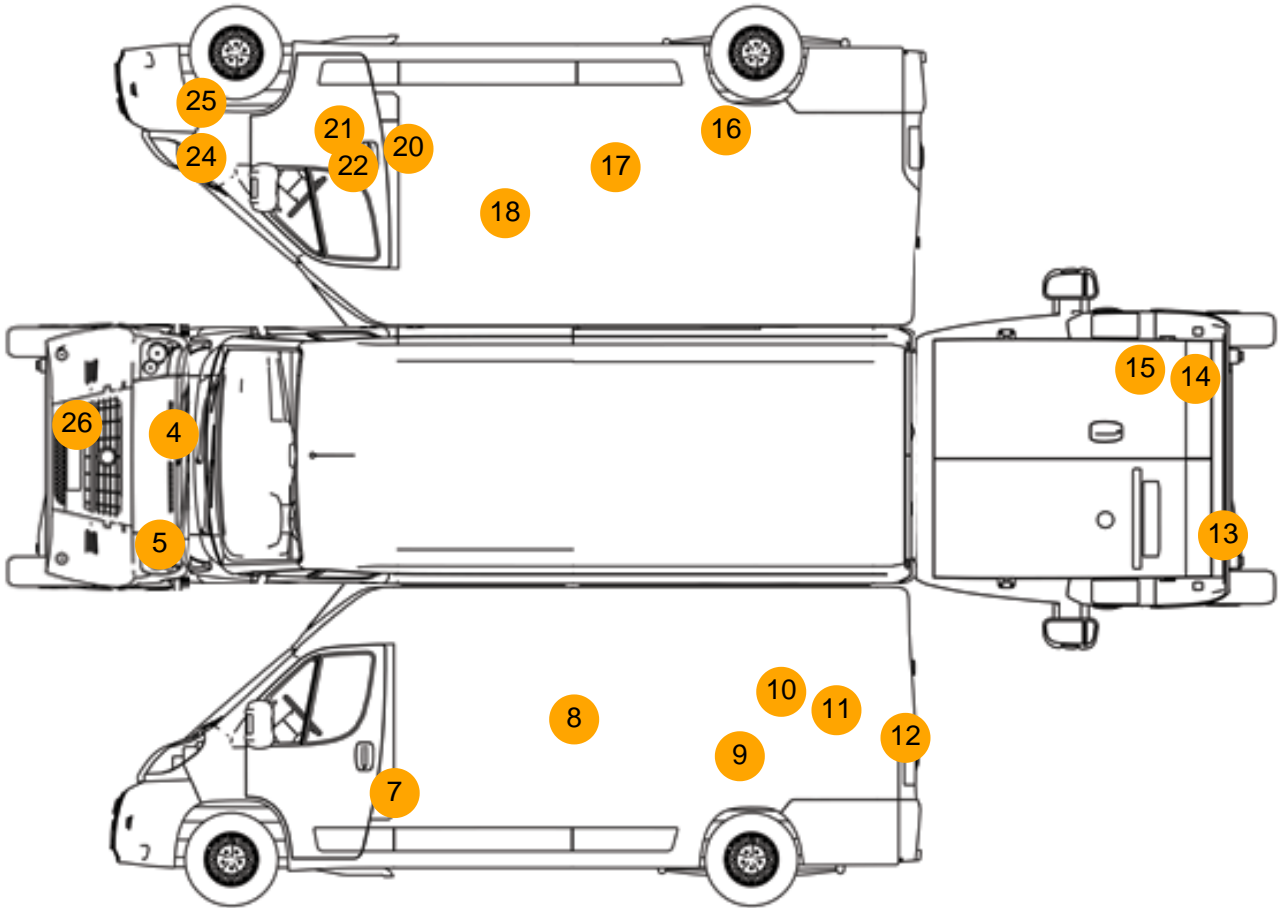

Damage Photos



1: Centre Console Front
Holed
Up To 3mm



2: Dash Warning Lights
Displayed
No Action



3: Seat Base Cover of
Holed
Over 3mm

4: Bonnet
Chipped
Multiple Chips



5: Bumper Front
Insecure
Action Required

6: Door nsf
Dented
With Paint Damage



7: Door nsf
Chipped
Multiple Chips

8: Qtr Panel nsr
Scratched
Over 25mm Thru Paint



9: Qtr Panel nsr
Scratched
Over 25mm Thru Paint

10: Qtr Panel nsr
Chipped
Over 5mm



11: Qtr Panel nsr
Dented
With Paint Damage

12: Panel Rear
Dented
With Paint Damage



13: Panel Rear
Scratched
Over 25mm Thru Paint

14: Panel Rear
Scratched
Over 25mm Thru Paint



15: Panel Rear
Rusted
Over 5mm

16: Qtr Panel osr
Scratched
Over 25mm Thru Paint



17: Qtr Panel osr
Poor Previous Repair
Paint Flake

18: Qtr Panel osr
Chipped
Multiple Chips



19: Qtr Panel osr
Scratched
Over 25mm Thru Paint

20: Door osf
Chipped
Multiple Chips



21: Door osf
Dented
Over 2 UpTo 10mm

22: Door osf
Scratched
Over 25mm Thru Paint



23: C Post os
Rusted
Over 5mm

24: Bumper Front
Poor Previous Repair
Poor Paint



25: Bumper Front
Scratched
UpTo 25mm Thru Paint

26: Bumper Front
Chipped
Multiple Chips

Interior

Carpet Condition	OK	Upholstery Condition	OK
Seat Condition	Poor	Odour	-
Engine Runs	OK	Gearbox 1st and Reverse Test	OK
Brakes	OK	Gearbox Static Gear Selection (engine running)	OK
Turbo Boosting	OK	No Excessive Smoking	OK
Parking Brake	OK		
EML light illuminated	Fault	DPF light illuminated	OK
ABS light illuminated	OK		