



**COMMERCIAL VEHICLE AUCTIONS LTD**  
THE UK'S MOST ESTABLISHED COMMERCIAL VEHICLE AUCTIONEERS

Carr Hill Industrial Estate  
Doncaster  
DN4 8DE

01302 732600 | cva.noreply@cva-auctions.co.uk

# VEHICLE INSPECTION REPORT

**BT20VVA**

## Ford Tourneo Custom 320 2.0 ECOBLUE 130PS ZETEC

Inspection		Vehicle	
Serious Damage?	No	VAT	Plus VAT
		V5	Buyer To Apply

### Details

Reg. date	31/07/2020	Colour	WHITE	CAP Average	£9,300.00
Year	2020	VIN	WF03XXTTG3LB74418	CAP Below	£7,425.00
Mileage	106,235 Miles Not Warranted	Body Style	Minibus	Gearbox	MANUAL
Fuel Type	Diesel	MOT Due	08/08/2026	Gears	6
GVW	1970kg	CAP Clean	£10,600.00		

\*PREVIOUSLY USED AS PRIVATE HIRE VEHICLE\* AD-BLUE, TWIN SIDE LOAD DOOR, E/ MIRRORS, HEATED WINDSCREEN

### Tyres

NSF
NSR
OSF
OSR
Spare

## Features

- Bluetooth connection
- Rear parking sensor
- Air conditioning
- Central locking
- Cruise control
- Auxiliary input socket
- Front electric windows
- Cloth seat trim
- Front parking sensor
- Digital radio
- Drivers airbag
- Heated front seat
- Mobile phone App interface
- Passenger airbag

## Photos



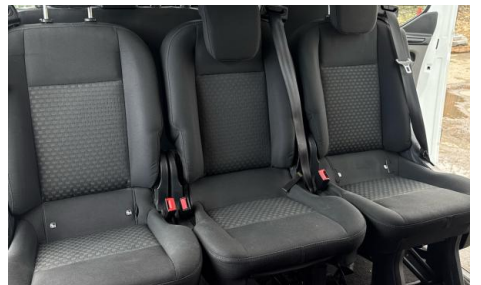
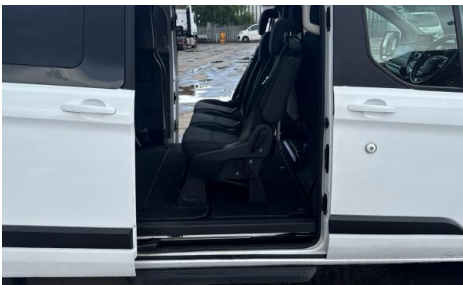
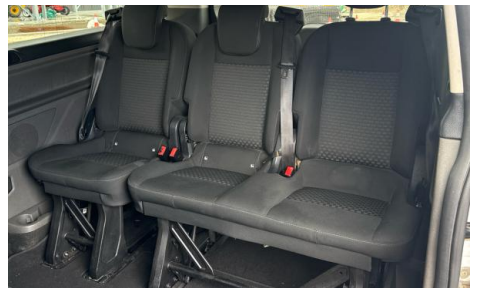
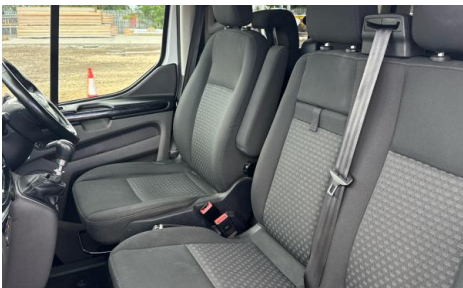
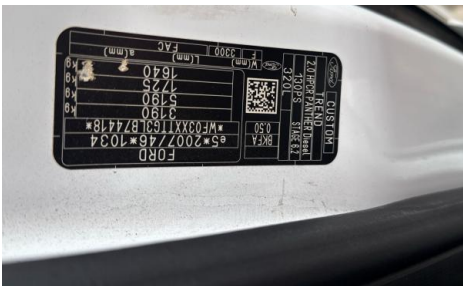
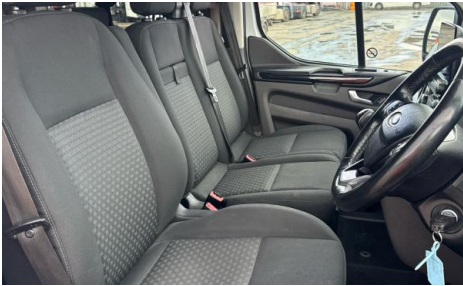
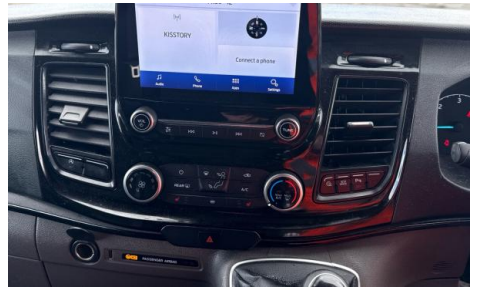



## Condition Check

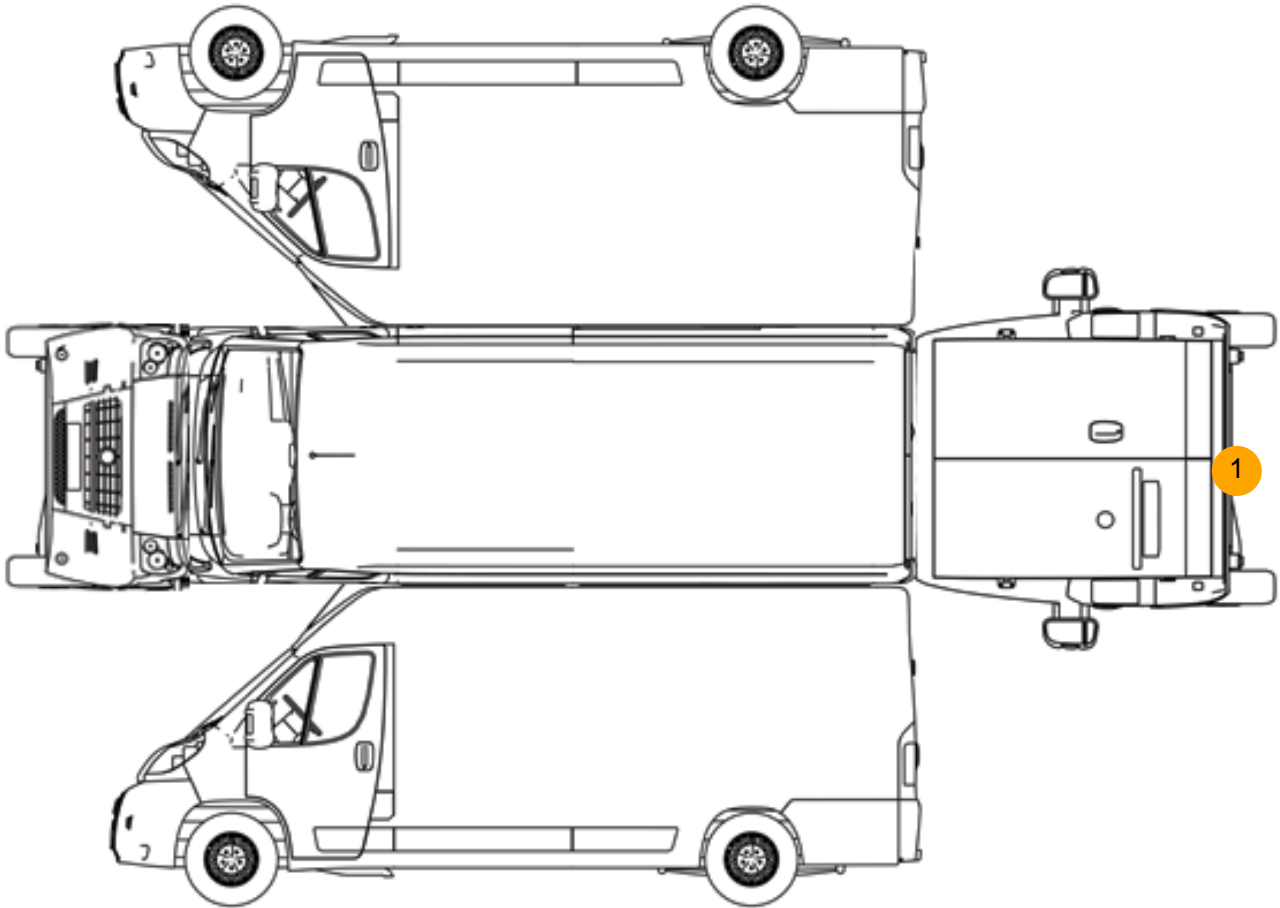

## Damage Photos



1: Bumper Rear  
Scratched  
Over 100mm Thru Paint

## Interior

**Carpet Condition**      OK  
**Seat Condition**        OK

**Upholstery Condition**    OK  
**Odour**                      No

Engine Runs	OK	Gearbox 1st and Reverse Test	OK
Brakes	OK	Clutch Slip Test from Static	OK
Turbo Boosting	OK	Gearbox Static Gear Selection (engine running)	OK
Parking Brake	OK	No Excessive Smoking	OK
EML light illuminated	OK	Oil warning light illuminated	OK
Airbag light illuminated	OK	DPF light illuminated	OK
ABS light illuminated	OK	Service indicator light illuminated	OK
Windows	OK	Radio	OK
		Steering	OK