



COMMERCIAL VEHICLE AUCTIONS LTD
THE UK'S MOST ESTABLISHED COMMERCIAL VEHICLE AUCTIONEERS

Carr Hill Industrial Estate
Doncaster
DN4 8DE

01302 732600 | cva.noreply@cva-auctions.co.uk

VEHICLE INSPECTION REPORT

LN67WTD

Ford Transit 350 2.0 TDCi 130ps

Inspection

Serious Damage? No

Vehicle

VAT Plus VAT

V5 Present

Details

Reg. date 30/09/2017

Year 2017

Mileage 197,698 Miles
Warranted

Fuel Type Diesel

GVW 3500kg

Colour GREEN

VIN WF0XXXTTGXHB72610

Body Style Panel Van L3

MOT Due 25/04/2027

CAP Clean £2,325.00

CAP Average £1,900.00

CAP Below £1,400.00

Gearbox MANUAL

Gears 6

AD-BLUE

Tyres

NSF

NSR

OSF

OSR

Spare

Features

- Bluetooth connection
- Drivers airbag
- Auxiliary input socket
- Central locking
- Digital radio
- Cloth seat trim
- Front electric windows

Photos



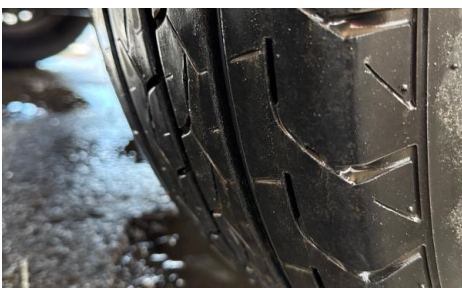
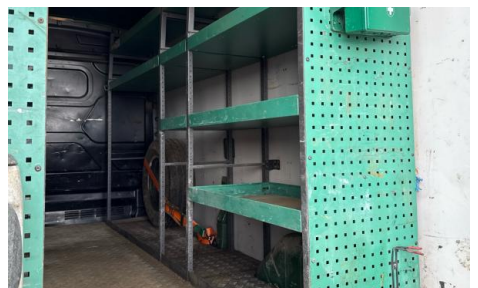
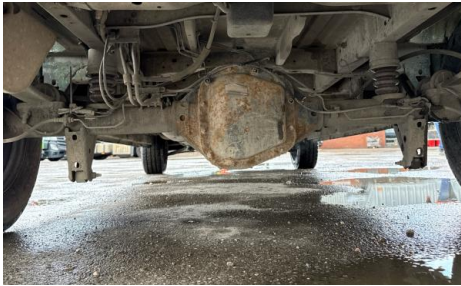



Condition Check

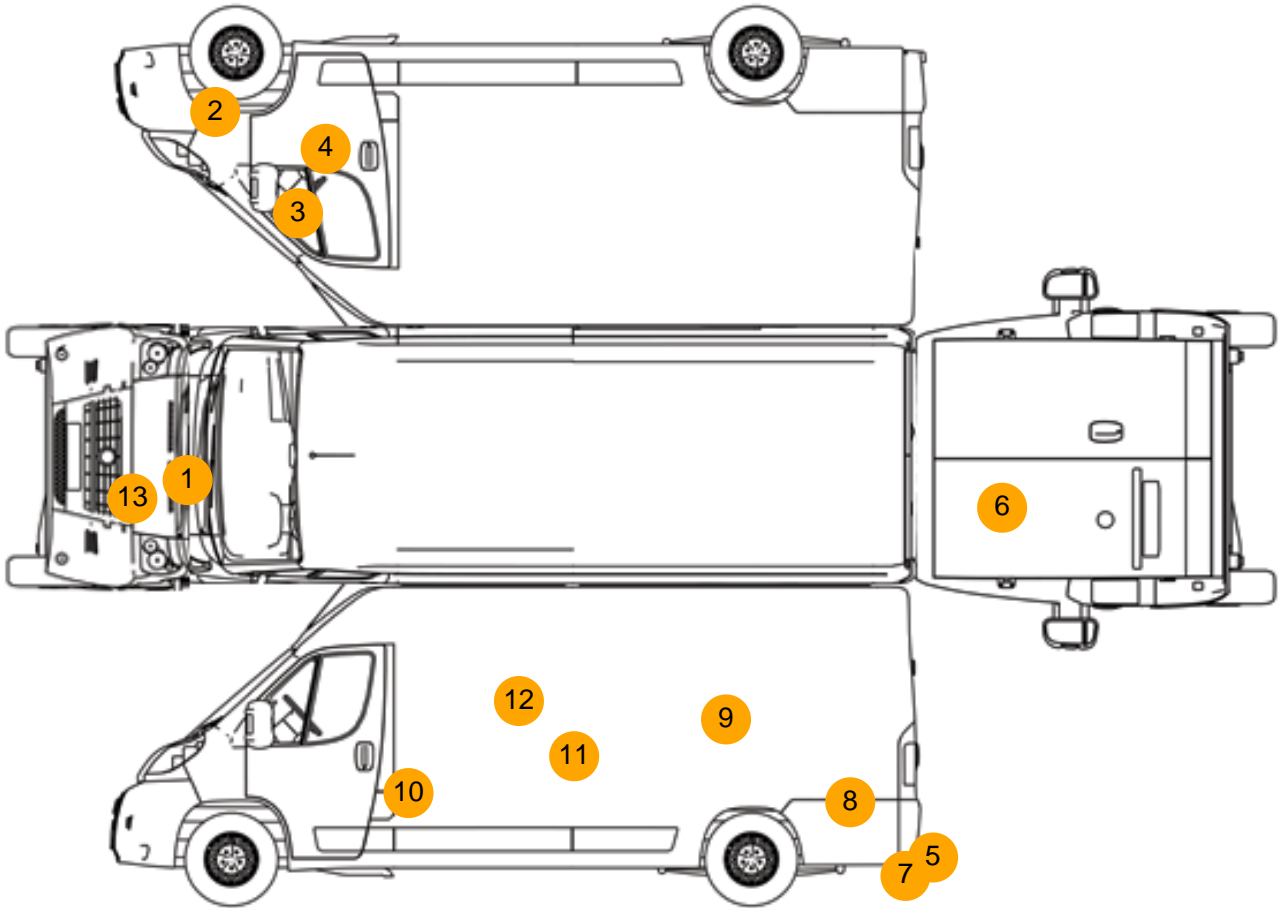

Damage Photos



1: Bonnet
Chipped
1 To 5

2: Wing of
Scratched
Over 25mm Not Thru Paint



3: Door Mirror Assy osf
Broken
Replace

4: Door osf
Scratched
UpTo 25mm Thru Paint



5: Bumper Rear Moulding
Broken
Replace

6: Door nsr
Dented
Between 10mm + 30mm



7: Bumper Rear Moulding
Scuffed (Unpainted)
Over 100mm

8: Panel Rear
Scratched
Over 25mm Not Thru Paint

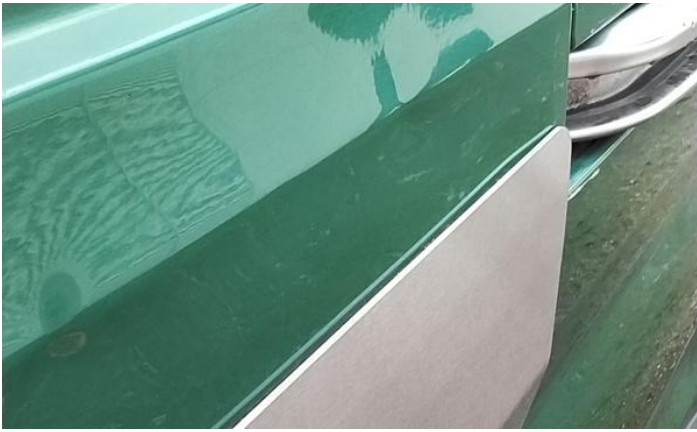

9: Panel Rear
Dented
2 Or Less UpTo 10mm

10: Door nsf
Chipped
Multiple Chips



11: Panel Rear
Scratched
Over 25mm Not Thru Paint

12: Panel Rear
Scratched
Over 25mm Not Thru Paint



13: Number Plate Front
Broken
Replace

Interior

Carpet Condition	Average	Upholstery Condition	Average
Seat Condition	Average	Odour	No
Engine Runs	OK	Gearbox 1st and Reverse Test	OK
Brakes	OK	Clutch Slip Test from Static	OK
Turbo Boosting	OK	Gearbox Static Gear Selection (engine running)	OK
Parking Brake	OK	No Excessive Smoking	OK
EML light illuminated	OK	Oil warning light illuminated	OK
Airbag light illuminated	OK	DPF light illuminated	OK
ABS light illuminated	OK	Service indicator light illuminated	OK
Windows	OK	Radio	OK
		Steering	OK